



**PARTS  
CATALOGUE  
CATALOGO  
DE REPUESTOS**

**60FET'15** (6CUG)

**60FETO'15** (6CUF)

**70BETO'15** (6H3F)

60FET  
60FETO/70BETO  
PARTS CATALOGUE  
©2015 by Yamaha Motor Co., Ltd.  
1st edition, July 2015  
All rights reserved.  
Any reprinting or unauthorized use  
without the written permission of  
Yamaha Motor Co., Ltd.  
is expressly prohibited.  
Printed in Japan.

60FET  
60FETO/70BETO  
CATALOGO DE REPUESTOS  
©2015 por Yamaha Motor Co., Ltd.  
1ª edición, julio 2015  
Todos los derechos reservados.  
Toda reproducción o uso no autorizado  
sin el consentimiento escrito de  
Yamaha Motor Co., Ltd.  
quedan expresamente prohibidos  
Impreso en Japón.

# FOREWORD

This Parts Catalogue is related to the parts for the model(s) on the cover page. When you are ordering replacement parts, please refer to this Parts Catalogue and quote both part numbers and part names correctly.

1. Modifications or additions which have been made after the issue of the Parts Catalogue will be announced in the Parts News.  
It is advisable that you make the necessary corrections to the Parts Catalogue according to the Parts News.

2. Abbreviations

The following abbreviations are used in this Parts Catalogue.

“UR” Use specified parts number.

“UN” Use as many as needed.

“AP” Alternate Parts

“LM” Locally Made (Parts need to be ordered locally)

“F#” Frame No. (Applicable machine No.)

“O/S” Over Size

3. The number of components for assembly

- Parts, which are to be supplied in an assembly, are listed with a dot (.) in front of the part name as shown below.
- The numeral appearing to the right of each component part indicates the quantity of parts for each assembly unit.

PART NO.	DESCRIPTION	Q'TY	REMARKS
2F5-83310-60	FRONT FLASHER LIGHT ASSY	2	
115-83311-60	.BULB (6V-18W)	1	

4. Applicable colours of graphics are represented in the “REMARKS” as shown below.

PART NO.	DESCRIPTION	Q'TY	REMARKS
2N4-24110-00-X5	FUEL TANK COMP.	2	MXR
3J1-24240-10	.GRAPHIC, FUEL TANK	1	FOR MXR

5. Note that the illustrations for reference in finding parts numbers are not to be used for assembling. When assembling, please use the applicable service manual.

6. The asterisk (\*) before a reference number indicates modified items after the first edition.

7. Applicable Serial No.

Engine Serial No.

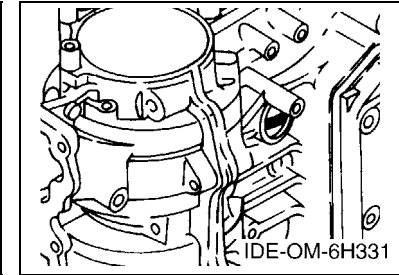
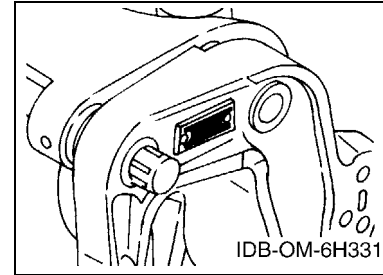

8. Applicable Engine Starting Serial No.

Model	Serial No.	Model	Serial No.
60F	6H2K-1016637	70B	6H3K-1016013

9. Applicable Colour Code

Abbreviation	Colour Name	Colour Code
DBNM2	DARK BLUISH GRAY METALLIC 2	004D

10. Quantity Column Information

Column No.	Name Of Q'ty Column	Applicable Model
1	ET	60FET
2	ETO	60FETO,70BETO

# PROLOGO

Este catálogo de repuestos corresponde a las piezas para el o los modelos que figuran en la página de portada. Al formular el pedido de repuestos, se ruega citar este catálogo y especificar correctamente el número y el nombre de las piezas.

- Las modificaciones y agregados que se hayan realizado después de la edición de este Catálogo de Repuestos, serán anunciados en las Informaciones de Recambios. Es recomendable que se hagan las correcciones necesarias en el Catálogo de Repuestos de acuerdo con las Informaciones de Recambios.

## 2. Abreviaciones

En este. Catálogo de Repuestos se emplean las siguientes abreviaciones.

“UR” Usar el número de partes especificado

“UN” Usar la cantidad necesaria

“AP” Piezas sustitutivas

“LM” Fabricación local (Hay que pedir los repuestos en las cercanías)

“F#” N° de bastidor (N° aplicable a la máquina)

“O/S” Sobredimensionado

## 3. La cantidad de componentes para el montaje

- Los componentes, suministrados como conjunto, se describen con un punto (.) que precede al nombre del parte como se indica a continuación.
- La numeración que aparece a la derecha de cada descripción indica la cantidad de partes por cada unidad de conjunto.

CODIGO N°	DESCRIPCION	CANT.	OBSERVACIONES
2F5-83310-60	ENSAMBLAJE DE LA LUZ	2	
115-83311-60	.BOMBILLA (6V-18W)	1	

## 4. Los colores de los componentes se indican como sigue en la columna de “OBSERVACIONES”.

CODIGO N°	DESCRIPCION	CANT.	OBSERVACIONES
2N4-24110-00-X5	COMP. DEL TANQUE	2	MXR
3J1-24240-10	.GRAFICO, DEL TANQUE	1	PARA MXR

- Debe tenerse en cuenta que las ilustraciones sirven como guía para la búsqueda de los números de partes y no deben usarse para el montaje. Durante el montaje, se recomienda usar el manual de taller correspondiente.

- EL asterisco (\*) antes del número de referencia indica los elementos modificados después de la primera edición.

## 7. Números de serie

N° de Serie del motor

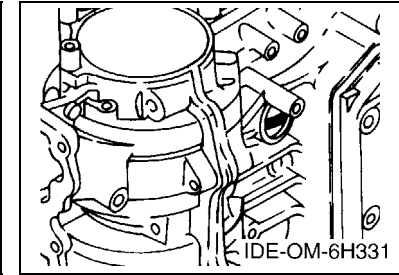
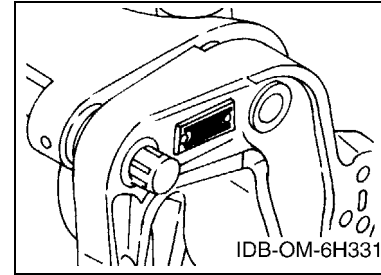

## 8. Números de serie del motor

Modelo	N° de serie	Modelo	N° de serie
60F	6H2K-1016637	70B	6H3K-1016013

## 9. Códigos de color aplicables

Abreviatura	Nombre de color	Código de color
DBNM2	DARK BLUISH GRAY METALLIC 2	004D

## 10. Informacion para la columna de cantidades

Columna N°	Nombre de la columna de cantidades	Modelo aplicable
1	ET	60FET
2	ETO	60FETO,70BETO

# CONTENTS

SCHEDULED SERVICE PARTS .....	1
TOP COWLING 1 .....	2
TOP COWLING 2 .....	3
CYLINDER & CRANKCASE .....	5
CRANKSHAFT & PISTON .....	7
INTAKE .....	8
CARBURETOR .....	10
OIL PUMP .....	13
FUEL .....	16
GENERATOR .....	18
ELECTRICAL .....	19
STARTING MOTOR .....	21
BOTTOM COWLING .....	22
CONTROL .....	24
BRACKET 1 .....	26
BRACKET 2 .....	28
POWER TRIM & TILT ASSY .....	30
UPPER CASING .....	33
LOWER CASING & DRIVE 1 .....	34
LOWER CASING & DRIVE 2 .....	38
FUEL TANK .....	40
STEERING GUIDE .....	41
REMOTE CONTROL BOX .....	42
REMOTE CONTROL ASSY 1 .....	43
REMOTE CONTROL ASSY 2 .....	46
METER 1 .....	49
METER 2 .....	50
REPAIR KIT 1 .....	51
REPAIR KIT 2 .....	53

## INDEX

NUMERICAL INDEX .....	55
-----------------------	----

# CONTENIDO

PARTES DE REPUESTO TEMPORALES .....	1
SOPORTE SUPERIOR 1 .....	2
SOPORTE SUPERIOR 2 .....	3
CYLINDRO & CARTER .....	5
CIGUENAL & PISTON .....	7
ADMISION .....	8
CARBURADOR .....	10
BOMBA DE ACEITE .....	13
COMBUSTIBLE .....	16
GENERADOR .....	18
ELECTRICO .....	19
MOTOR DE ARRANQUE .....	21
CUBIERTA INFERIOR .....	22
CONTROL .....	24
SOPORTE 1 .....	26
SOPORTE 2 .....	28
COMPONER Y PODER VARILLA .....	30
FUNDA SUPERIOR .....	33
IMPULSOR E INFERIOR 1 .....	34
IMPULSOR E INFERIOR 2 .....	38
DEPOSITO DE COMBUSTIBLE .....	40
DIRECCIONGUIAR .....	41
CONTROL REMOTO COMPLETO .....	42
CONTROL REMOTO COMPL 1 .....	43
CONTROL REMOTO COMPL 2 .....	46
MEDIDOR 1 .....	49
MEDIDOR 2 .....	50
ESTUCHE REPARATION 1 .....	51
ESTUCHE REPARATION 2 .....	53

## INDICE

INDICE NUMERICO .....	55
-----------------------	----

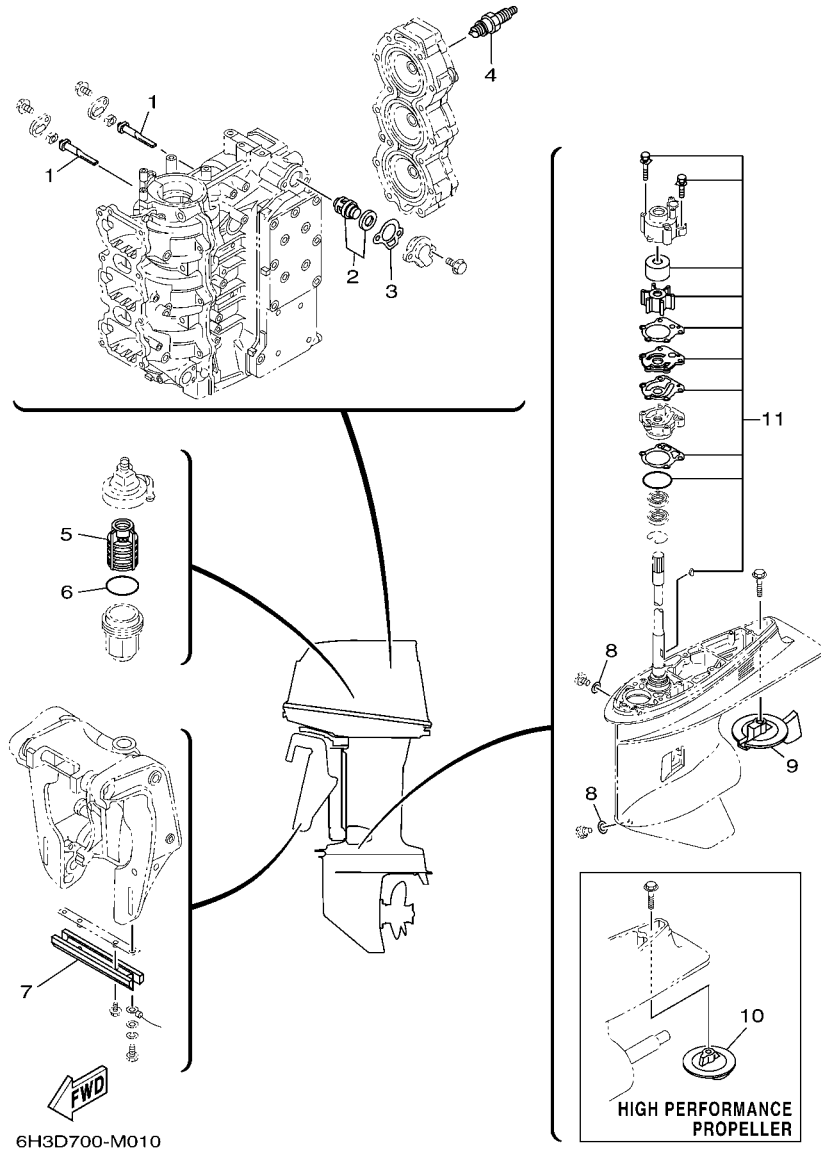
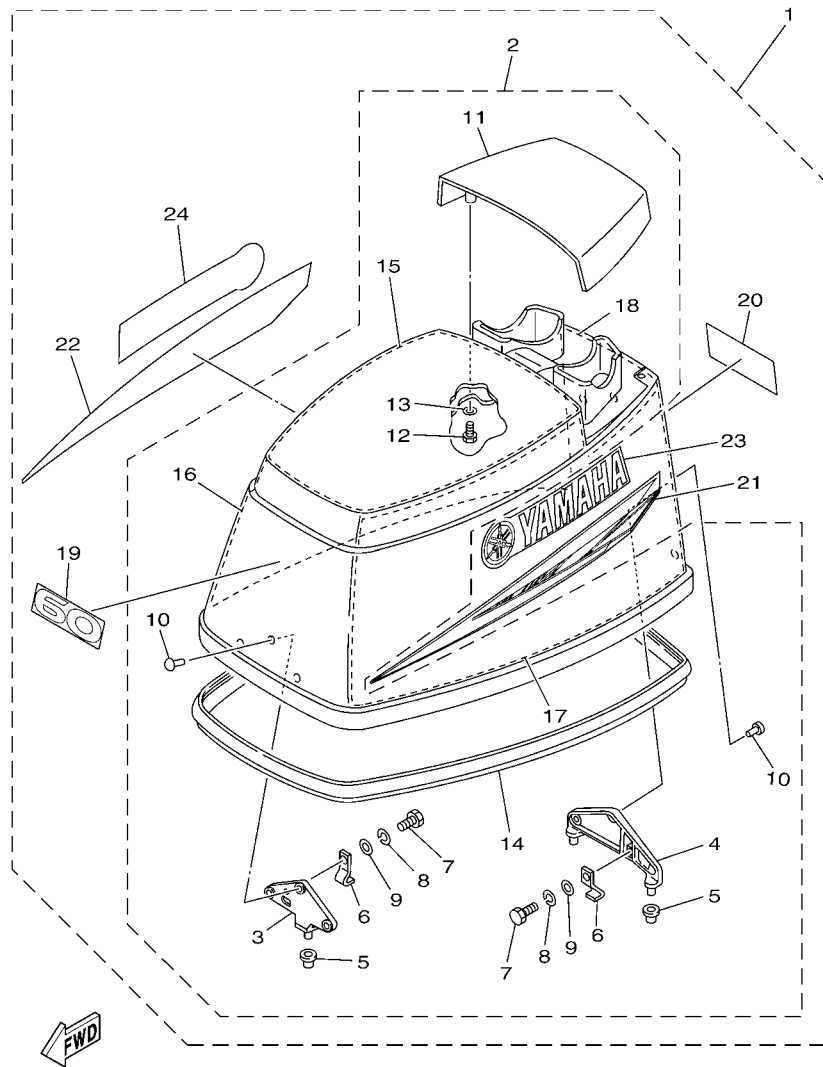

FIG. 1 SCHEDULED SERVICE PARTS PARTES DE REPUESTO TEMPORALES

REF. NO.	PART NO. CODIGO Nº	DESCRIPTION DESCRIPCION	ET	EYO	REMARKS OBSERVACIONES
1	6H3-11325-01	ANODE ANODO	2	2	
2	6H3-12411-11	THERMOSTAT TERMOSTAT	1	1	
3	6H3-12414-A1	GASKET, COVER EMPAQUE	1	1	
4	94702-00160	PLUG, SPARK (NGK B8HS-10) BUJIA (NGK B8HS-10)	3	3	UR
	94702-00247	PLUG, SPARK (NGK BR8HS-10) BUJIA (NGK BR8HS-10)	3	3	UR
5	61N-24563-00	ELEMENT, FILTER ELEMENTO DEL FILTRO	1	1	
6	93210-32738	O-RING ANILLO O	1	1	
7	6H1-45251-03	ANODE CATODE	1	1	
8	90430-08020	GASKET JUNTA	2	2	
9	67F-45371-00	TAB-TRIM QUILLA ESTABILIZADOR	1	1	
10	6E5-45371-10	TAB-TRIM QUILLA ESTABILIZADOR	1	1	
11	692-W0078-02	WATER PUMP REPAIR KIT ESTUCHE REPARACION BOMBA AGUA	1	1	



6H3E200-N020

FIG. 2 TOP COWLING 1

SOPORTE SUPERIOR 1

REF. NO.	PART NO. CODIGO Nº	DESCRIPTION DESCRIPCION	ET	ETO	REMARKS OBSERVACIONES
1	6H2-42610-10	TOP COWLING ASSY SOPORTE SUPERIOR COMPL.	1		60F 60F
2	6H3-4261A-00	..TOP COWLING W/O GRAPHICS ..SOPORTE SUPERIOR SIN GRAFICOS	1		
3	6H3-42647-00	..HOLDER, CLAMP BAND ..MORDAZA DE ABRAZADERA	1		
4	6H3-42649-00	..HOLDER, CLAMP BAND ..MORDAZA DE ABRAZADERA	1		
5	663-42662-00	..DAMPER ..AMORTIGUADOR	3		
6	6H3-42652-00	..HOOK ..GANCHO	2		
7	97095-06016	..BOLT ..PERNO	2		
8	92995-06100	..WASHER, SPRING ..ARANDELA	2		
9	92995-06600	..WASHER ..ARANDELA	2		
10	90266-06009	..RIVET ..REMACHE	6		
11	6H3-42613-01-4D	..MOLDING, AIR DUCT ..MOLDURA CONDUCTO AIRE	1		
12	97095-06016	..BOLT ..PERNO	4		
13	92995-06600	..WASHER ..ARANDELA	4		
14	6H3-42615-00	..SEAL ..SELLO	1		
15	6H3-42617-00	..DAMPER, FORM ..HULE DE FORMA	1		
16	6H3-42619-00	..DAMPER, FORM ..HULE DE FORMA	1		
17	6H3-42627-00	..DAMPER, FORM ..AMORTIGUADOR FORMA 3	1		
18	6H3-42637-00	..DAMPER, FORM ..HULE DE FORMA	1		
19	6H2-42678-10	..GRAPHIC, REAR ..CALCAMONIA TRASERA	1		
20	6H2-42678-10	..GRAPHIC, REAR ..CALCAMONIA TRASERA	1		
21	688-42675-40	..GRAPHIC, SIDE 1 ..CALCAMONIA LATERAL 1	1		
22	688-42676-40	..GRAPHIC, SIDE 2 ..CALCAMONIA LATERAL 2	1		
23	688-42681-40	..MARK, COWLING ..MARCA DE CUBIERTA	1		
24	688-42681-40	..MARK, COWLING ..MARCA DE CUBIERTA	1		



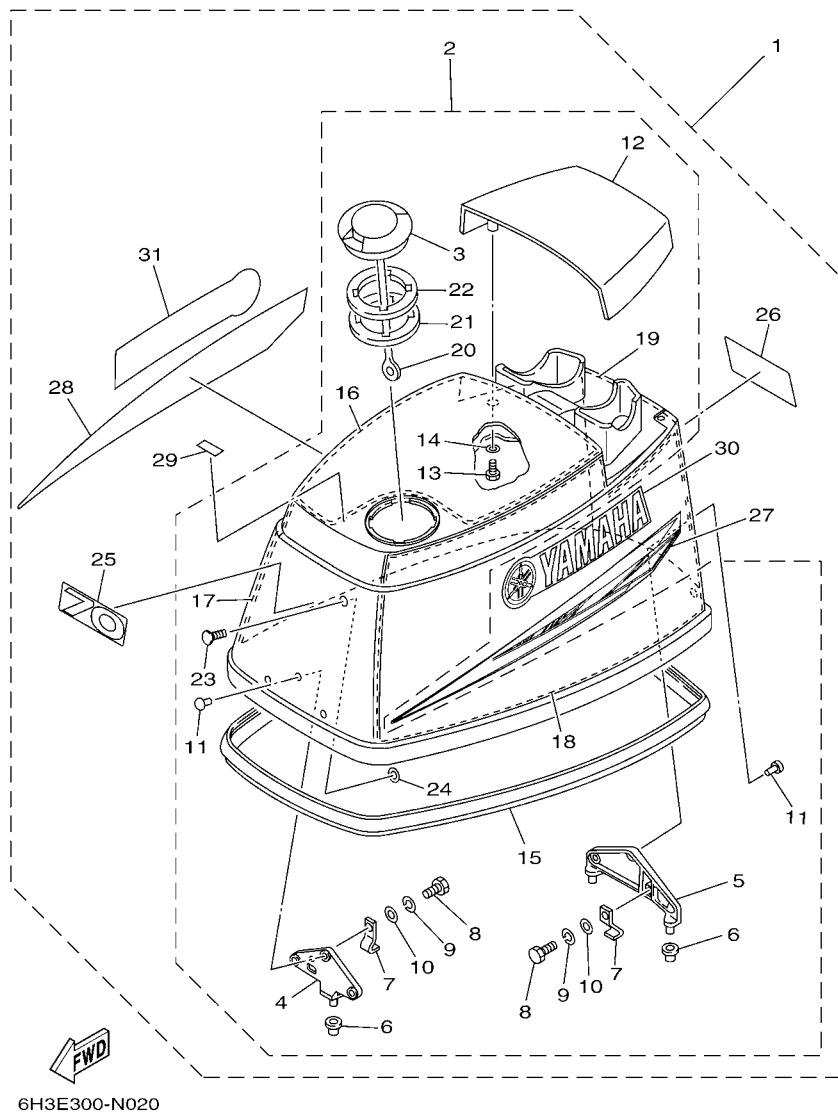
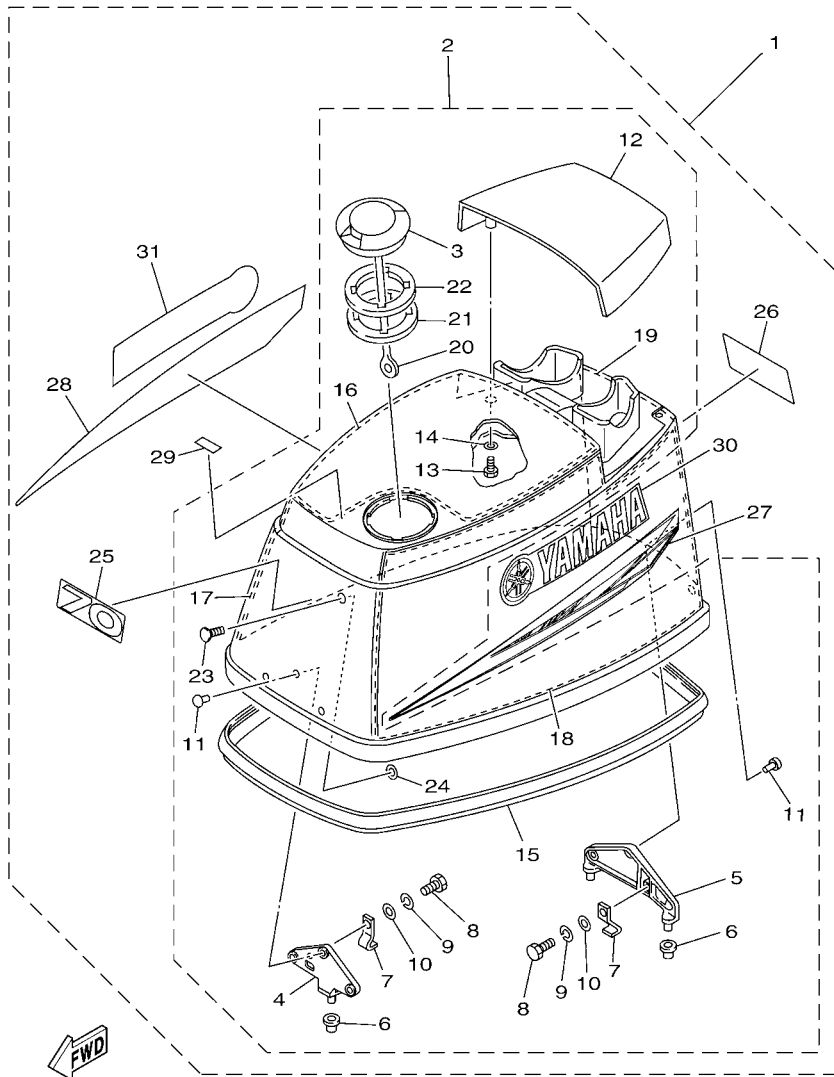

FIG. 3 TOP COWLING 2

SOPORTE SUPERIOR 2

REF. NO.	PART NO. CODIGO Nº	DESCRIPTION DESCRIPCION	ET	EYO	REMARKS OBSERVACIONES
1	6H3-42610-00	TOP COWLING ASSY SOPORTE SUPERIOR COMPL.		1	70B 70B
	6H2-42610-70	TOP COWLING ASSY SOPORTE SUPERIOR COMPL.		1	60F 60F
2	6H3-4261A-10	..TOP COWLING W/O GRAPHICS ..SOPORTE SUPERIOR SIN GRAFICOS		1	
3	63D-2177H-00	..DISK CAP 2 ..TAPA DE DISCO 2		1	
4	6H3-42647-00	..HOLDER, CLAMP BAND ..MORDAZA DE ABRAZADERA		1	
5	6H3-42649-00	..HOLDER, CLAMP BAND ..MORDAZA DE ABRAZADERA		1	
6	663-42662-00	..DAMPER ..AMORTIGUADOR		3	
7	6H3-42652-00	..HOOK ..GANCHO		2	
8	97095-06016	..BOLT ..PERNO		2	
9	92995-06100	..WASHER, SPRING ..ARANDELA		2	
10	92995-06600	..WASHER ..ARANDELA		2	
11	90266-06009	..RIVET ..REMACHE		6	
12	6H3-42613-01-4D	..MOLDING, AIR DUCT ..MOLDURA CONDUCTO AIRE		1	
13	97095-06016	..BOLT ..PERNO		4	
14	92995-06600	..WASHER ..ARANDELA		4	
15	6H3-42615-00	..SEAL ..SELLO		1	
16	6H3-42617-10	..DAMPER, FORM ..HULE DE FORMA		1	
17	6H3-42619-00	..DAMPER, FORM ..HULE DE FORMA		1	
18	6H3-42627-00	..DAMPER, FORM ..AMORTIGUADOR FORMA 3		1	
19	6H3-42637-00	..DAMPER, FORM ..HULE DE FORMA		1	
20	6H1-42694-00	..BAND ..ABRAZADERA		1	
21	6H3-21732-00	..SEAL 1 ..SELLO 1		1	
22	6H3-21735-00	..SEAL 2 ..SELLO 2		1	
23	90338-05M03	..PLUG ..TAPON		1	
24	90183-05M06	..NUT, SPRING ..TUERCA DE RESORTE		1	
25	6H3-42678-10	..GRAPHIC, REAR ..CALCAMONIA TRASERA		1	70B 70B
	6H2-42678-10	..GRAPHIC, REAR ..CALCAMONIA TRASERA		1	60F 60F



6H3E300-N020

FIG. 3 TOP COWLING 2

SOPORTE SUPERIOR 2

REF. NO.	PART NO. CODIGO Nº	DESCRIPTION DESCRIPCION	ET	EYO	REMARKS OBSERVACIONES
26	6H3-42678-10	.GRAPHIC, REAR .CALCAMONIA TRASERA		1	70B 70B
	6H2-42678-10	.GRAPHIC, REAR .CALCAMONIA TRASERA		1	60F 60F
27	688-42675-40	.GRAPHIC, SIDE 1 .CALCAMONIA LATERAL 1		1	
28	688-42676-40	.GRAPHIC, SIDE 2 .CALCAMONIA LATERAL 2		1	
29	6H3-13436-00	.MARK .MARCA		1	70B 70B
	6H3-13436-40	.MARK .MARCA		1	60F 60F
30	688-42681-40	.MARK, COWLING .MARCA DE CUBIERTA		1	
31	688-42681-40	.MARK, COWLING .MARCA DE CUBIERTA		1	

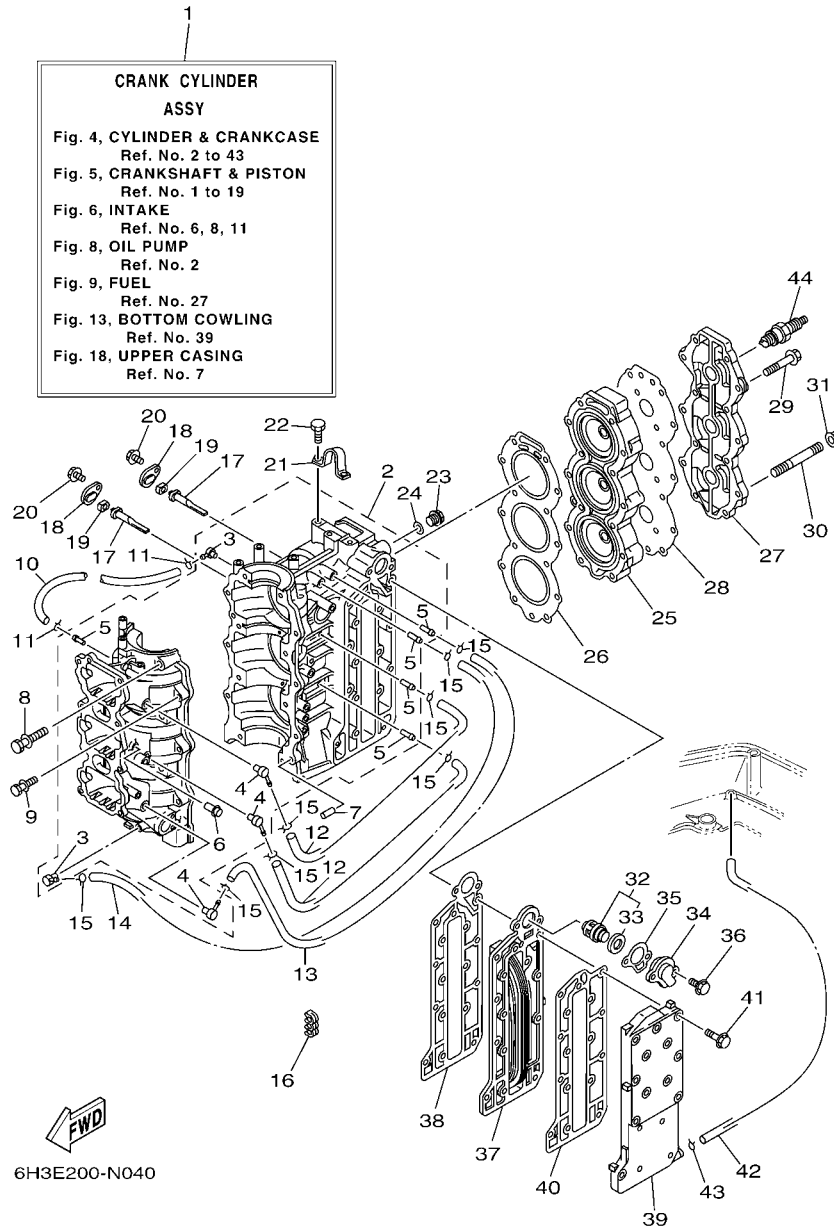

**FIG. 4 CYLINDER & CRANKCASE CYLINDRO & CARTER**

REF. NO.	PART NO. CODIGO Nº	DESCRIPTION DESCRIPCION	ET	EPO	REMARKS OBSERVACIONES
1	6H3-W0090-44-1S	CRANK CYLINDER ASSY BLOQUE MOTOR COMPLETO		1	60F,70B-O/I 60F,70B-O/I
	6H3-W0090-60-1S	CRANK CYLINDER ASSY BLOQUE MOTOR COMPLETO	1		60F-N.O/I 60F-N.O/I
2	6H3-15100-14	CRANKCASE ASSY CARTER COMPLETO		1	60F,70B-O/I 60F,70B-O/I
	6H3-15100-06	CRANKCASE ASSY CARTER COMPLETO	1		60F-N.O/I 60F-N.O/I
3	688-11370-01	.CHECK VALVE ASSY .VALVULA DE CONTROL COMPL.	2	2	
4	650-11370-01	.CHECK VALVE ASSY .VALVULA DE CONTROL COMPL.	3	3	
5	624-14485-00	.PIPE, JOINT .TUBO DE UNION	5	5	
6	650-24378-00	.PIPE, JOINT 4 .TUBO DE UNION 3	1	1	
7	93608-12063	PIN, DOWEL PASADOR DE CLAVIJA	2	2	
8	90119-10005	BOLT, WITH WASHER TORNILLO CON ARANDELA	8	8	
9	90119-08M64	BOLT, WITH WASHER TORNILLO CON ARANDELA	6	6	
10	90445-07M44	HOSE (L250) TUBO (L250)	1	1	
11	90467-06016	CLIP PRESILLA	2	2	
12	90445-07M02	HOSE (L167) TUBO (L167)	2	2	
13	90445-07M45	HOSE (L340) TUBO (L340)	1	1	
14	90445-07M82	HOSE (L440) TUBO (L440)	1	1	
15	90467-06016	CLIP PRESILLA	8	8	
16	90464-07M05	CLAMP BRIDA	1	1	
17	6H3-11325-01	ANODE ANODO	2	2	
18	6H3-11327-00-94	COVER, ANODE CUBIERTA DE ANODO	2	2	
19	6H3-11328-00	GROMMET, ANODE TAPON	2	2	
20	90119-06023	BOLT, WITH WASHER TORNILLO CON ARANDELA	2	2	
21	688-11119-01	HANGER, ENGINE SOPORTE DEL MOTOR	1	1	
22	90101-08002	BOLT TORNILLO	2	2	
23	90340-14M06	PLUG, STRAIGHT SCREW TORNILLO, DE DRENAJE	1	1	
24	90430-14115	GASKET JUNTA	1	1	
25	6H3-11111-01-1S	HEAD, CYLINDER 1 CULATA CILINDRO 1	1	1	

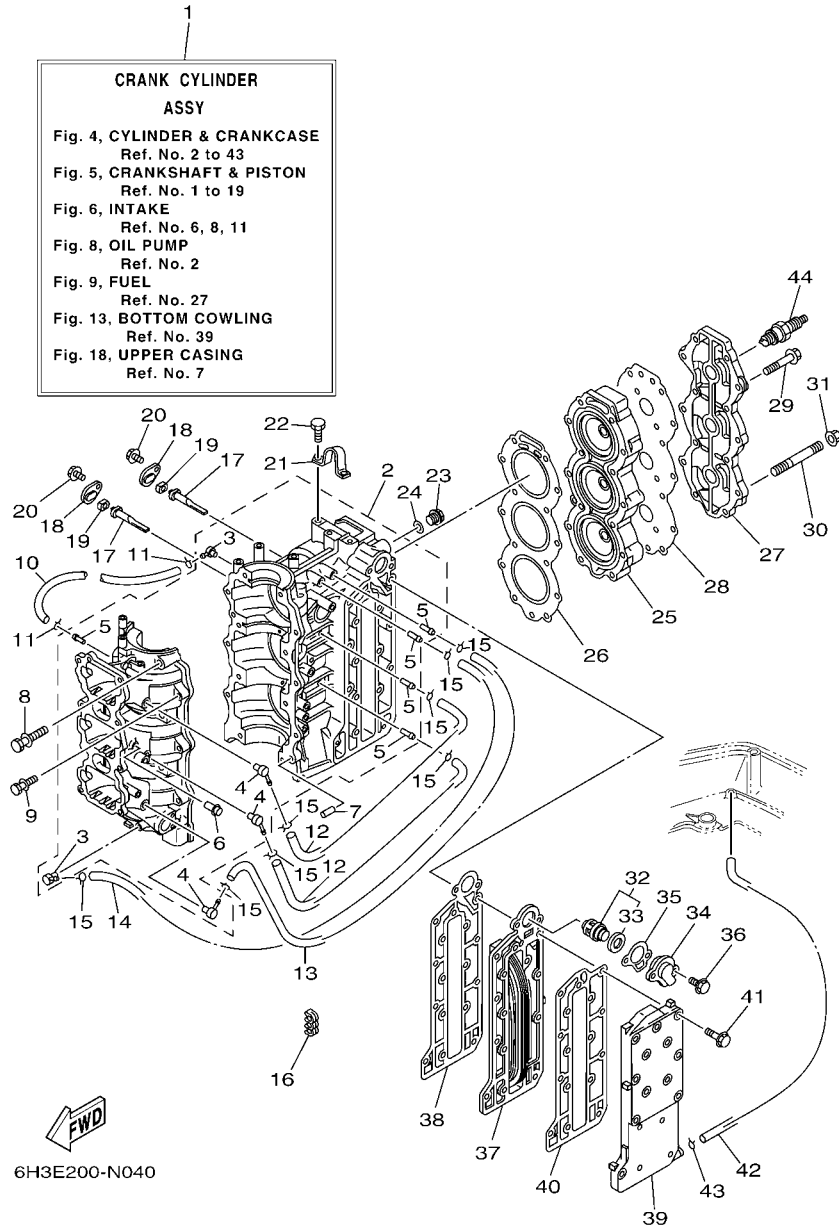

**FIG. 4 CYLINDER & CRANKCASE CYLINDRO & CARTER**

REF. NO.	PART NO. CODIGO Nº	DESCRIPTION DESCRIPCION	ET	ETO	REMARKS OBSERVACIONES
26	6H3-11181-A2	GASKET, CYLINDER HEAD 1 JUNTA, DE CULATA 1	1	1	
27	6H3-11191-00-1S	COVER, CYLINDER HEAD 1 TAPA CULATA DE CILINDRO 1	1	1	
28	6H3-11193-A1	GASKET, HEAD COVER 1 EMPAQUE	1	1	
29	90119-08MA5	BOLT, WITH WASHER TORNILLO CON ARANDELA	13	13	
30	90116-08M69	BOLT, STUD ESPARRAGO	1	1	
31	90179-08M34	NUT TUERCA	1	1	
32	6H3-12411-11	THERMOSTAT TERMOSTAT	1	1	
33	688-12412-00	.SEAL, THERMOSTAT .SELLO TERMOSTATO	1	1	
34	6H3-12413-00-1S	COVER, THERMOSTAT CUBIERTA TERMOSTATO	1	1	
35	6H3-12414-A1	GASKET, COVER EMPAQUE	1	1	
36	90119-06MA3	BOLT, WITH WASHER TORNILLO CON ARANDELA	2	2	
37	6H3-41111-01-1S	INNER COVER, EXHAUST CUBIERTA INTERIOR DE ESCAPE	1	1	
38	6H3-41112-A0	GASKET, EXHAUST INNER COVER EMPAQUE	1	1	
39	6H3-41113-02-1S	OUTER COVER, EXHAUST CUBIERTA EXTERIOR DE ESCAPE	1	1	
40	6H3-41114-A0	GASKET, EXHAUST OUTER COVER EMPAQUE	1	1	
41	90119-06MA5	BOLT, WITH WASHER TORNILLO CON ARANDELA	16	16	
42	663-24312-01	PIPE 2 TUBO 2	1	1	
43	90467-08004	CLIP PRESILLA	1	1	
44	94702-00160	PLUG, SPARK (NGK B8HS-10) BUJIA (NGK B8HS-10)	3	3	CAR,BRA,AFR,OTH
	94702-00247	PLUG, SPARK (NGK BR8HS-10) BUJIA (NGK BR8HS-10)	3	3	CAR(CE),ARG,RUS,CHN CAR(CE),ARG,RUS,CHN

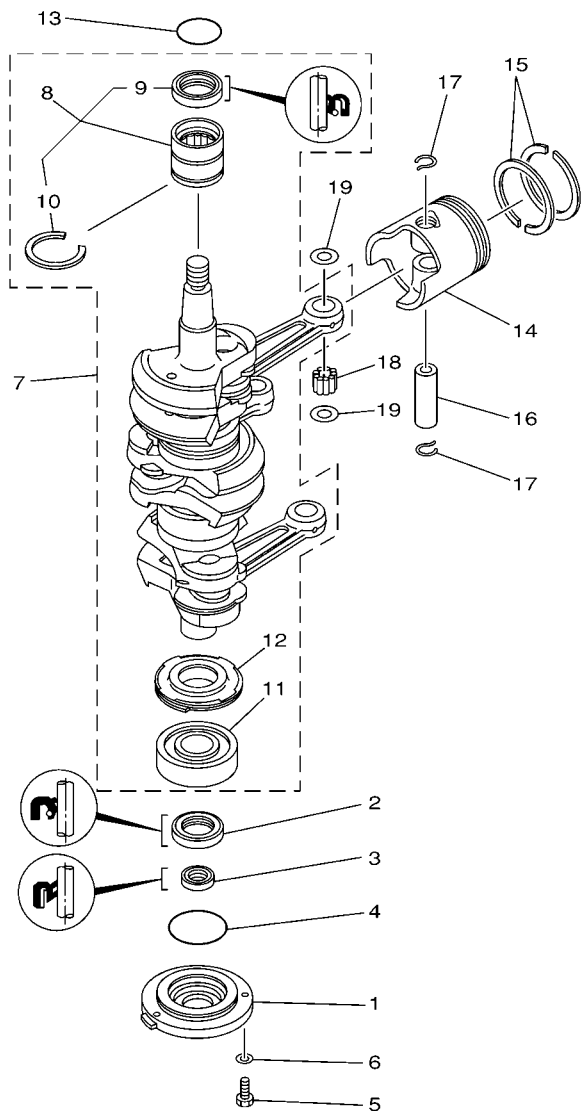

6H30010-9030

FIG. 5 CRANKSHAFT & PISTON CIGUENAL & PISTON

REF. NO.	PART NO. CODIGO Nº	DESCRIPTION DESCRIPCION	ET	EPO	REMARKS OBSERVACIONES
1	6H3-15359-00-94	HOUSING, OIL SEAL CAJA DE SELLO DE ACEITE	1	1	
2	93102-30M23	OIL SEAL SELLO ACEITE	1	1	
3	93106-18M01	OIL SEAL SELLO ACEITE	1	1	
4	93210-65M50	O-RING ANILLO O	1	1	
5	97095-06020	BOLT PERNO	3	3	
6	92995-06600	WASHER ARANDELA	3	3	
7	6H3-11400-10	CRANKSHAFT ASSY CIGUENAL COMPLETO		1	60F,70B-O/I 60F,70B-O/I
	6H3-11400-03	CRANKSHAFT ASSY CIGUENAL COMPLETO		1	60F-N.O/I 60F-N.O/I
8	93311-636U6	.BEARING .COJINETE DE RODILLOS	1	1	
9	93102-36M24	..OIL SEAL ..SELLO ACEITE	1	1	
10	93440-49M04	..CIRCLIP ..SEGURO	1	1	
11	93306-306V1	.BEARING .COJINETE	1	1	
12	6H3-11536-00	.GEAR, DRIVE .ENGRANAJE TRACCION		1	FOR 6H3-11400-10 FOR 6H3-11400-10
13	93210-46M16	O-RING ANILLO O	1	1	
14	6H3-11631-01-96	PISTON (STD) PISTON (NORMA)	3	3	
	6H3-11635-01	PISTON (0.25MM O/S) PISTON (0.25MM O/S)	3	3	AP AP
	6H3-11636-01	PISTON (0.50MM O/S) PISTON (0.50MM O/S)	3	3	AP AP
15	6K5-11601-02	PISTON RING SET (STD) JUEGO DE AROS (NORMA)	3	3	
	6K5-11601-12	PISTON RING SET (0.25MM O/S) JUEGO DE AROS (0.25MM O/S)	3	3	AP AP
	6K5-11601-22	PISTON RING SET (0.50MM O/S) JUEGO DE AROS (0.50MM O/S)	3	3	AP AP
16	6H3-11633-00	PIN, PISTON PASADOR, PISTON	3	3	
17	688-11634-10	CLIP, PISTON PIN PRESILLA, BULON DE PISTON	6	6	
18	93603-18M09	PIN, DOWEL PASADOR DE CLAVIJA	84	84	
19	90201-20417	WASHER, PLATE ARANDELA PLANA	6	6	

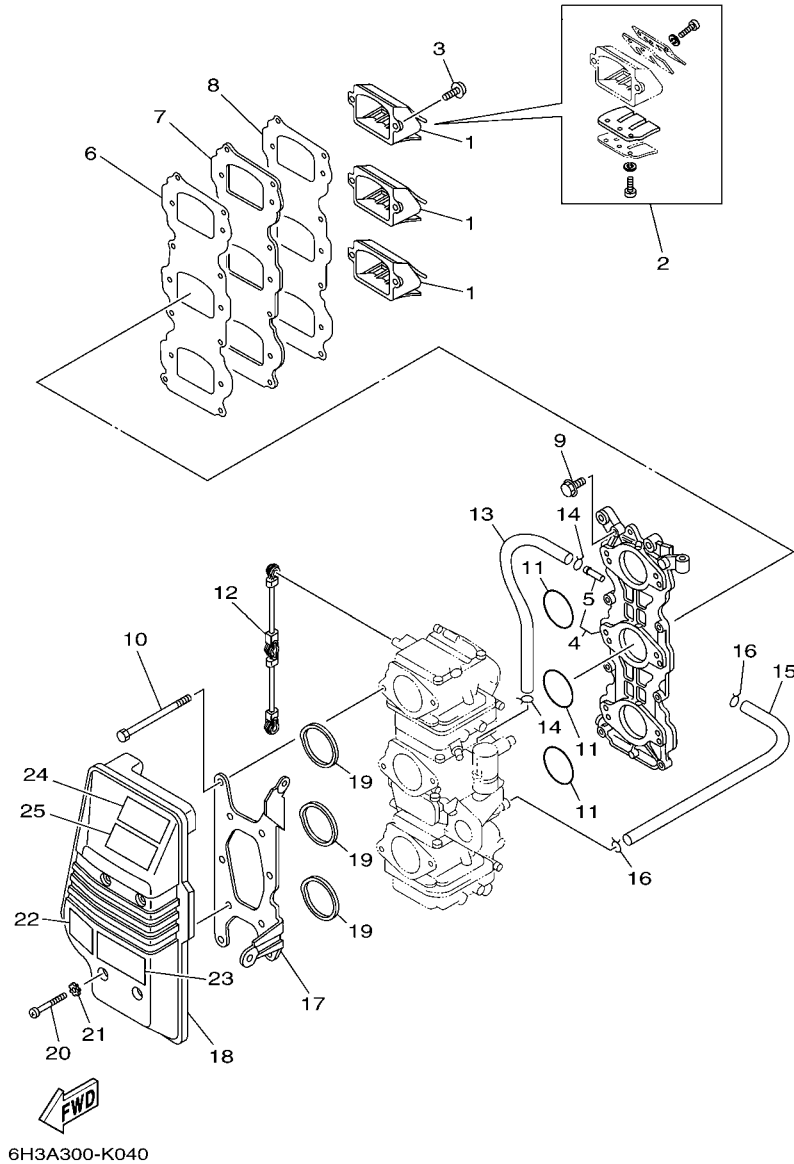

FIG. 6 INTAKE

ADMISION

REF. NO.	PART NO. CODIGO Nº	DESCRIPTION DESCRIPCION	ET	EPO		REMARKS OBSERVACIONES
1	6H3-13610-00	REED VALVE ASSY VALVULA DE LAMINAS COMPLETA		3		70B 70B
	6H2-13610-00	REED VALVE ASSY VALVULA DE LAMINAS COMPLETA		3	3	60F 60F
2	688-W0004-00	.REED SET .JUEGO DE VALVULAS DE LENGUETA	1	1		
3	97980-05216	SCREW, WITH WASHER TORNILLO, CON ARANDELA	6	6		
4	6H3-13641-14	MANIFOLD, INTAKE 1 CONECTOR DE ADMISION 1		1		60F,70B-O/I 60F,70B-O/I
	6H3-13641-22	MANIFOLD, INTAKE 1 CONECTOR DE ADMISION 1		1		60F-N.O/I 60F-N.O/I
5	6H1-14485-00	.PIPE, JOINT .TUBO DE UNION		4		FOR 6H3-13641-14 FOR 6H3-13641-14
	6H1-14485-00	.PIPE, JOINT .TUBO DE UNION		1		FOR 6H3-13641-22 FOR 6H3-13641-22
6	6H3-13621-A1	GASKET, VALVE SEAT JUNTA, DE VALV.DE EMPAQUE	1	1		
7	6H3-13624-00	PLATE, REED VALVE PLACA DE VALVULA DE LAMINAS	1	1		
8	6H3-13622-A1	GASKET, VALVE SEAT EMPAQUE DE ASIENTO VALVULA	1	1		
9	90119-06MA3	BOLT, WITH WASHER TORNILLO CON ARANDELA	8	8		
10	97095-06095	BOLT PERNO	6	6		
11	93210-39ME4	O-RING ANILLO O	3	3		
12	6H3-41217-00	ROD, ACCEL. LEVER VARILLA PALANCA ACELERADOR	1	1		
13	90445-07255	HOSE (L160) TUBO (L160)	1	1		
14	90467-06016	CLIP PRESILLA	2	2		
15	6H3-14349-00	PIPE TUBO	1	1		
16	90467-08004	CLIP PRESILLA	2	2		
17	6H3-14413-11	STAY SOPORTE	1	1		
18	6H3-14440-02	SILENCER ASSY, INTAKE SILENCIADOR COMPL DE ADMISION	1	1		
19	6H3-14457-01	SEAL SELLO	3	3		
20	97885-06045	SCREW, PAN HEAD TORNILLO A MUESCA	4	4		
21	90209-06M05	WASHER ARANDELA DE SEPARACION	4	4		
22	6H1-85711-60	MARK, CAUTION MARKER	1	1		
23	6K5-14488-00	LABEL, CAUTION ETIQUETA PRECAUCION	1	1		
24	6EE-81994-40	LABEL, SAFETY ETIQUETA DE SEGURIDAD	1	1		EXCEPT FOR BRA EXCEPT FOR BRA

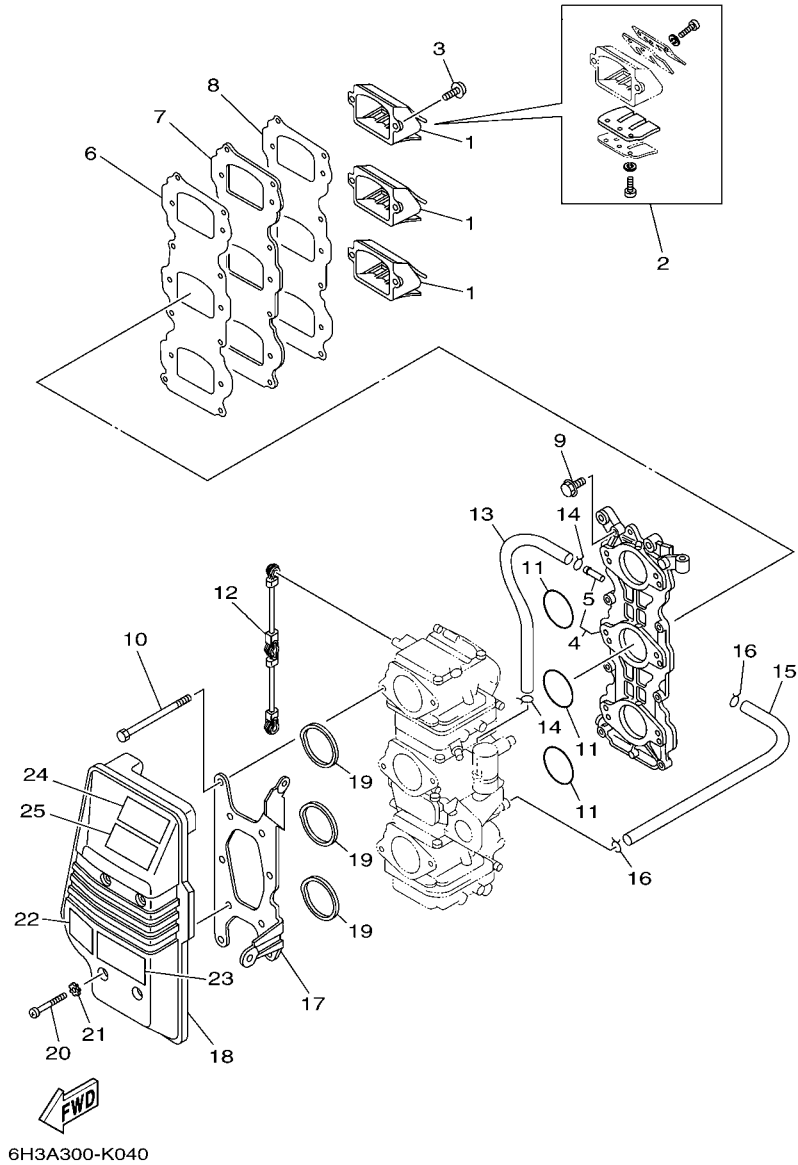

FIG. 6 INTAKE

ADMISION

REF. NO.	PART NO. CODIGO Nº	DESCRIPTION DESCRIPCION	ET	ETO	REMARKS OBSERVACIONES
24	6AH-81994-70	LABEL, SAFETY ETIQUETA DE SEGURIDAD		1	FOR BRA FOR BRA
25	6EE-81994-50	LABEL, SAFETY ETIQUETA DE SEGURIDAD		1	FOR RUS FOR RUS
-----					
-----					
-----					
-----					
-----					
-----					
-----					
-----					
-----					
-----					
-----					
-----					
-----					
-----					
-----					
-----					
-----					

FIG. 7 CARBURETOR

CARBURADOR

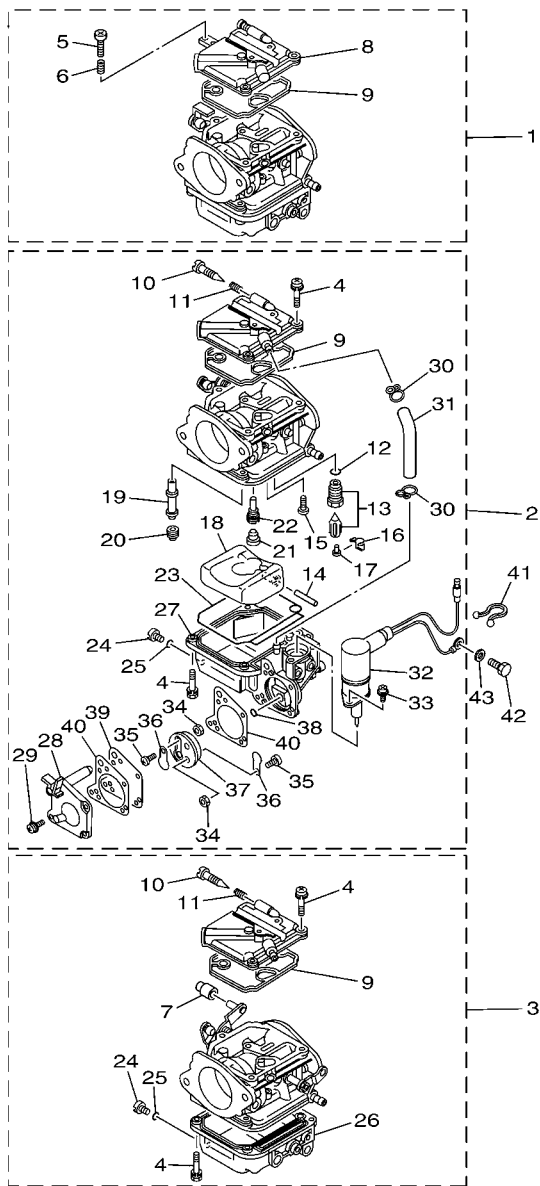

  
6H3D700-M060

REF. NO.	PART NO. CODIGO Nº	DESCRIPTION DESCRIPCION	ET	EPO	REMARKS OBSERVACIONES
1	6H3-14301-20	CARBURETOR ASSY 1 CARBURADOR COMPLETO 1		1	70B 70B
	6H2-14301-40	CARBURETOR ASSY 1 CARBURADOR COMPLETO 1	1	1	60F 60F
	6H2-14301-50	CARBURETOR ASSY 1 CARBURADOR COMPLETO 1		1	60F-BRA 60F-BRA
2	6H3-14302-20	CARBURETOR ASSY 2 CARBURADOR COMPLETO 2		1	70B 70B
	6H2-14302-40	CARBURETOR ASSY 2 CARBURADOR COMPLETO 2	1	1	60F 60F
	6H2-14302-50	CARBURETOR ASSY 2 CARBURADOR COMPLETO 2		1	60F-BRA 60F-BRA
3	6H3-14303-20	CARBURETOR ASSY 3 CARBURADOR COMPLETO 3		1	70B 70B
	6H2-14303-40	CARBURETOR ASSY 3 CARBURADOR COMPLETO 3	1	1	60F 60F
	6H2-14303-50	CARBURETOR ASSY 3 CARBURADOR COMPLETO 3		1	60F-BRA 60F-BRA
4	97980-04114	.SCREW, WITH WASHER .TORNILLO, CON ARANDELA	21	21	
5	63V-14523-00	.SCREW, STOP .TORNILLO DE TOPE	1	1	#1 #1
6	90501-10326	.SPRING, COMPRESSION .RESORTE DE COMPRESION	1	1	#1 #1
7	6H2-14578-00	.COLLAR .COLLAR	1	1	#3 #3
8	6H4-14146-00	.PLATE .PLACA SOPORTE	1	1	#1 #1
9	6H4-14147-00	.O-RING .ANILLO O	3	3	
10	692-14923-00	.SCREW, PILOT .TORNILLO DE AJUSTE	3	3	
11	697-14555-00	.SPRING .RESORTE	4	4	
12	93210-04228	.O-RING .ANILLO O	3	3	
13	6H3-14590-01	.NEEDLE VALVE ASSY .VALVULA DE AGUJA COMPLETA	3	3	
14	6H4-14548-00	.PIN, FLOAT ARM .PASADOR DE BRAZO DE BOIA	3	3	
15	98580-04008	.SCREW, PAN HEAD .TORNILLO DE CABEZA CRUZADA	3	3	
16	663-14159-00	.CLIP .PRESILLA	3	3	
17	676-14186-00	.PIN, FLOAT .PASADOR DE LA BOYA	3	3	
18	6H4-14985-01	.FLOAT .BOIA	3	3	
19	6H3-14947-71	.JET, NEEDLE .INYECTOR DE AGUJA		3	70B 70B
	6H2-14947-71	.JET, NEEDLE .INYECTOR DE AGUJA	3	3	60F 60F
20	6H3-14943-37	.JET, MAIN (#150) .INYECTOR PRINCIPAL (#150)		3	70B 70B



FIG. 7 CARBURETOR

CARBURADOR

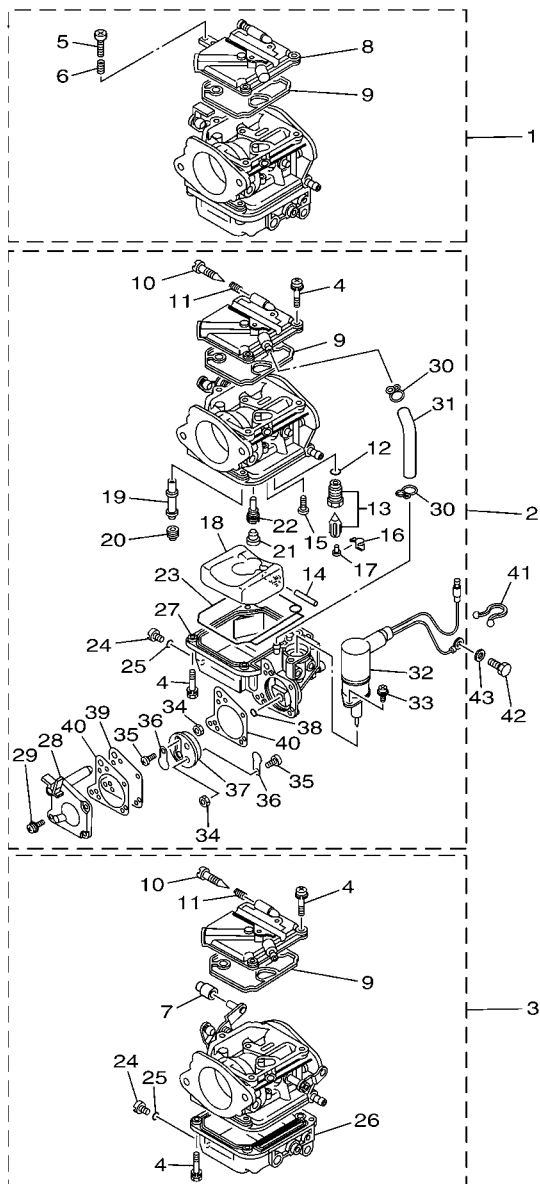

6H3D700-M060

REF. NO.	PART NO. CODIGO Nº	DESCRIPTION DESCRIPCION	LET	EPO	REMARKS OBSERVACIONES
20	6H3-14943-35	.JET, MAIN (#140) .INYECTOR PRINCIPAL (#140)	2	2	60F-#1,2 60F-#1,2
	676-14943-38	.JET, MAIN (#155) .INYECTOR PRINCIPAL (#155)		2	60F-#1,2 BRA 60F-#1,2 BRA
	6H3-14943-36	.JET, MAIN (#145) .INYECTOR PRINCIPAL (#145)	1	1	60F-#3 60F-#3
	6H1-14943-39	.JET, MAIN (#160) .INYECTOR PRINCIPAL (#160)		1	60F-#3 BRA 60F-#3 BRA
21	676-14966-00	.CAP .TAPA	3	3	
22	6H3-14948-17	.JET (#75) .INYECTOR (#75)		3	70B 70B
	6H3-14948-13	.JET (#65) .INYECTOR (#65)	3	3	60F 60F
	6H3-14948-16	.JET (#72) .INYECTOR (#72)		3	60F-BRA 60F-BRA
23	6H4-14984-00	.GASKET, FLOAT CHAMBER .EMPAQUE CAMARA DE BOIA	3	3	
24	6H3-14992-00	.SCREW, DRAIN .TORNILLO, SEGURO	3	3	
25	93210-04230	.O-RING .ANILLO O	3	3	
26	6H4-14980-00	.BODY, FLOAT CHAMBER .CUERPO CAMARA DE BOIA	2	2	#1,3 #1,3
27	6H3-14980-10	.BODY, FLOAT CHAMBER .CUERPO CAMARA DE BOIA	1	1	#2 #2
28	6H3-24452-10	.COVER .CUBIERTA	1	1	#2 #2
29	6H4-14567-00	.SCREW .TORNILLO	4	4	#2 #2
30	6H3-14137-00	.CLIP .PRESILLA	2	2	#2 #2
31	6H3-14349-00	.PIPE .TUBO	1	1	#2 #2
32	6H3-14380-00	.STARTER ASSY .ARRANQUE COMPLETO	1	1	#2 #2
33	97803-04010	.SCREW, PAN HEAD .TORNILLO CABEZA ABULTADA	2	2	#2 #2
34	95380-03600	.NUT .TUERCA	2	2	#2 #2
35	98980-03006	.SCREW, BIND .TORNILLO DE LIGAR	2	2	#2 #2
36	6L5-24421-00	.VALVE, CHECK .VALVULA DE RETENCION	2	2	#2 #2
37	6H4-24413-00	.BODY 2 .CUERPO 2	1	1	#2 #2
38	6H4-24486-00	.O-RING .ANILLO O	1	1	#2 #2
39	6H3-24411-10	.DIAPHRAGM .DIAFRAGMA	1	1	#2 #2
40	6H3-24434-10	.GASKET, BODY .EMPAQUE	2	2	#2 #2
41	90465-18147	.CLAMP .BRIDA	1	1	

FIG. 7 CARBURETOR

CARBURADOR

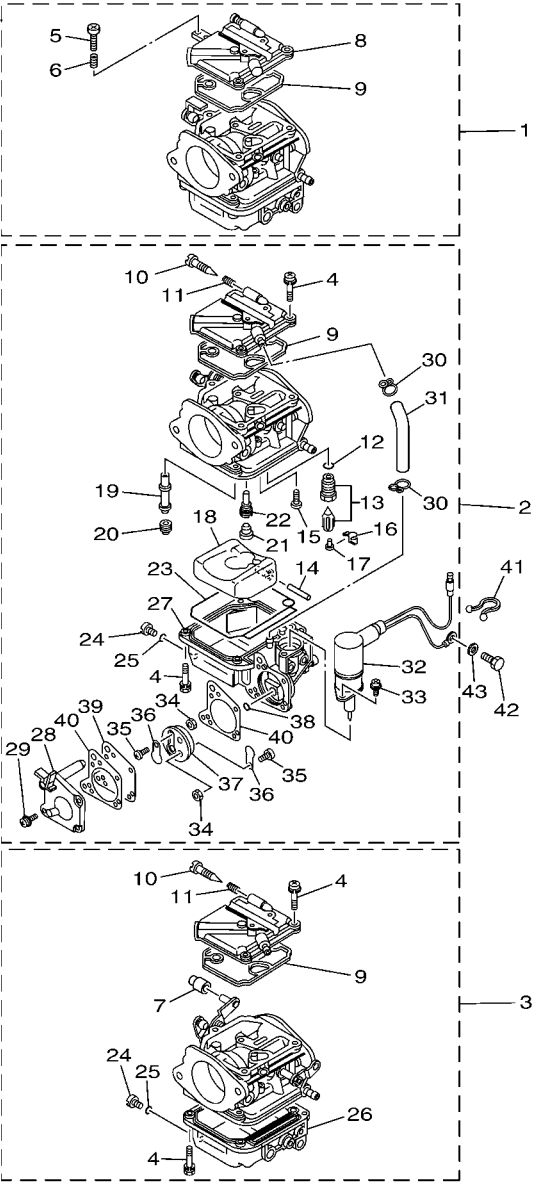

6H3D700-M060

REF. NO.	PART NO. CODIGO Nº	DESCRIPTION DESCRIPCION	ET	ETO			REMARKS OBSERVACIONES
42	97013-06012	BOLT PERNO	1	1			
43	92903-06600	WASHER, PLATE RONDANA SENCILLA	1	1			

FIG. 8 OIL PUMP

BOMBA DE ACEITE

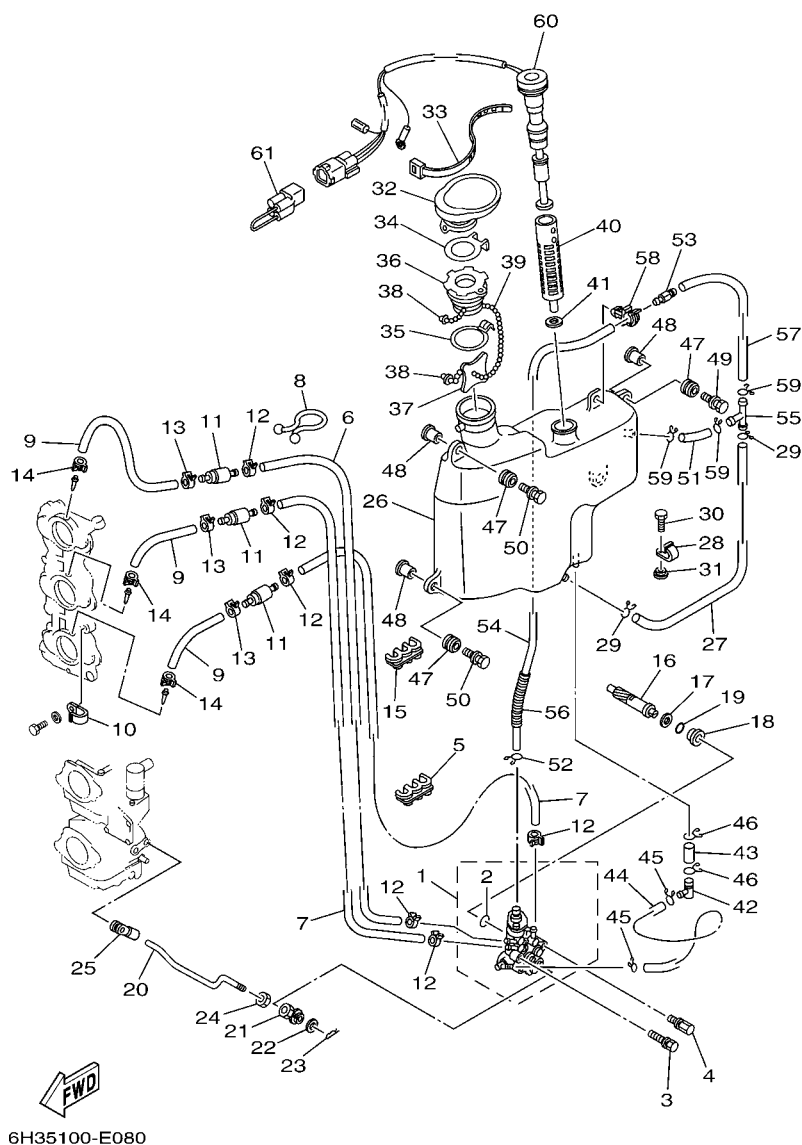

6H35100-E080

REF. NO.	PART NO. CODIGO Nº	DESCRIPTION DESCRIPCION	ET	E/O	REMARKS OBSERVACIONES
1	6H3-13200-02	OIL INJECTION PUMP ASSY BOMBA DE ACEITE COMPLETA		1	
2	93210-19MA7	.O-RING .ANILLO O		1	
3	90109-06M39	BOLT PERNO		1	
4	90109-06M40	BOLT PERNO		1	
5	90464-07M05	CLAMP BRIDA		1	
6	90445-07M44	HOSE (L250) TUBO (L250)		1	
7	90445-07M23	HOSE (L408) TUBO (L408)		2	
8	90464-15M11	CLAMP BRIDA		1	
9	90445-07M87	HOSE (L110) TUBO (L110)		3	
10	90465-06M86	CLAMP BRIDA		1	
11	6E9-13183-70	VALVE, CHECK VALVULA DE RETENTION		3	
12	90468-07M02	CLIP PRESILLA		6	
13	90468-07M02	CLIP PRESILLA		3	
14	90468-07M02	CLIP PRESILLA		3	
15	90464-07M05	CLAMP BRIDA		1	
16	6H3-11537-01	GEAR, DRIVEN ENGRANAJE TRACCION		1	
17	90201-08M93	WASHER, PLATE ARANDELA PLANA		1	
18	6H1-13117-01	COLLAR, DISTANCE COLLAR, DISTANCIA		1	
19	93210-13M04	O-RING ANILLO O		1	
20	6H3-41241-01	ROD, LINK VARILLA		1	
21	6H1-41237-00	JOINT, LINK CONECTOR		1	
22	90202-05088	WASHER, PLATE ARANDELA DE PLANA		1	
23	90468-05M03	CLIP PRESILLA		1	
24	95380-05600	NUT TUERCA		1	
25	6E9-41237-00	JOINT, LINK CONECTOR		1	
26	6H3-21707-06	OIL TANK COMP. DEPOSITO DE ACEITE COMP.		1	
27	90445-11M03	HOSE (L330) TUBO (L330)		1	

FIG. 8 OIL PUMP

BOMBA DE ACEITE

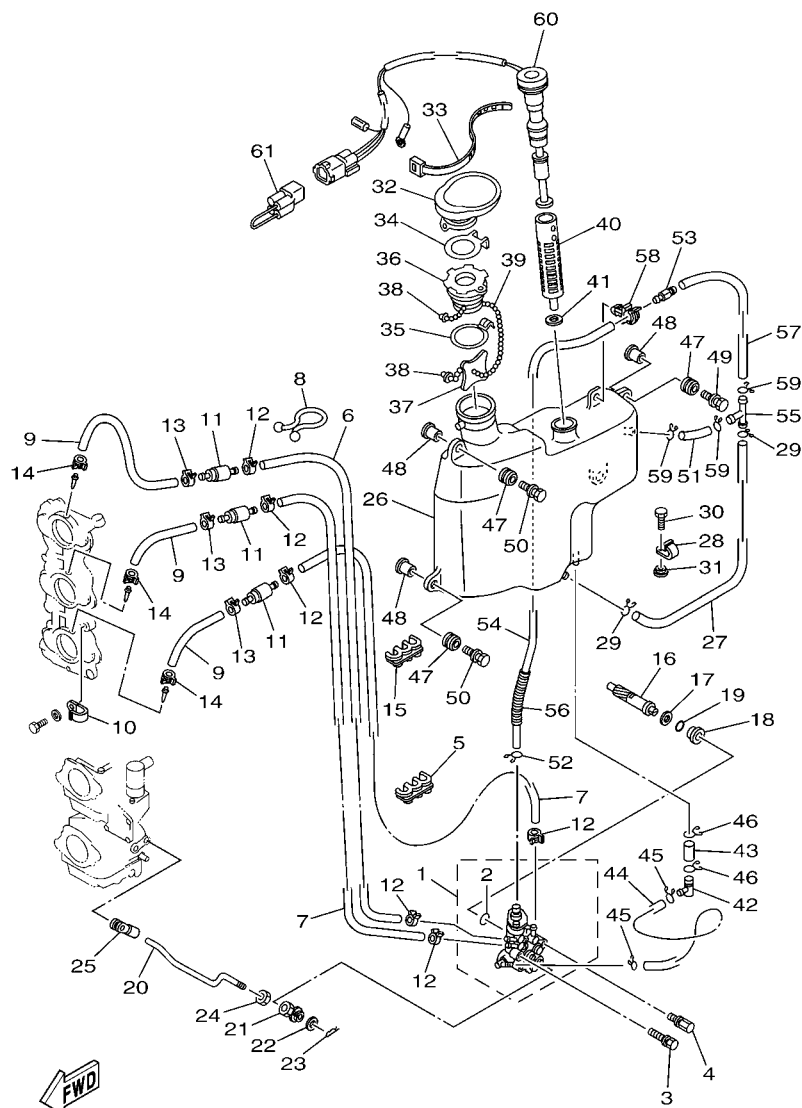

6H35100-E080

REF. NO.	PART NO. CODIGO Nº	DESCRIPTION DESCRIPCION	ET	ETO	REMARKS OBSERVACIONES
28	90465-11M27	CLAMP BRIDA		1	
29	90467-11M08	CLIP PRESILLA		2	
30	97095-06016	BOLT PERNO		1	
31	90387-06M31	COLLAR ESPACIADOR		1	
32	6H3-21752-00	TUBE, FILLER 1 TUBO DE LLENADOR 1		1	
33	90465-13M30	CLAMP BRIDA		1	
34	63D-2176M-00	HOOK GANCHO		1	
35	63D-2175R-00	HOOK, BAND GANCHO DE CINTA		1	
36	6H4-21770-00	OIL TANK CAP ASSY TAPA DE DEPOSITO DE ACEITE		1	
37	6J8-21758-00	WASHER, SPECIAL 2 ARANDELA ESPECIAL 2		1	
38	6H1-21757-00	WASHER, SPECIAL 1 ARANDELA ESPECIAL 1		2	
39	6H1-24633-00	CHAIN, BALL EMPAQUE		1	
40	6J8-13411-00	STRAINER, OIL FILTRO DE ACEITE		1	
41	6J8-13414-00	GASKET, STRAINER COVER EMPAQUE DE TAPA FILTRO		1	
42	6H1-13435-00	NIPPLE NIPLE		1	
43	90445-08M01	HOSE (L30) TUBO (L30)		1	
44	6H1-21766-01	PIPE, OIL TUBO DEL ACEITE		1	
45	90467-08004	CLIP PRESILLA		2	
46	90467-12M11	CLIP PRESILLA		2	
47	6A0-82317-00	DAMPER, IGNITION COIL AMORTIGUADOR BOBINA ENCENDIDO		4	
48	90387-06119	COLLAR ESPACIADOR		4	
49	90119-06M65	BOLT, WITH WASHER TORNILLO CON ARANDELA		2	
50	90119-06M88	BOLT, WITH WASHER TORNILLO CON ARANDELA		2	
51	90445-11M21	HOSE (L40) TUBO (L40)		1	
52	90467-10M04	CLIP PRESILLA		1	
53	63D-21744-00	BREATHER RESPIRADERO		1	
54	90445-11M15	HOSE (L360) TUBO (L360)		1	

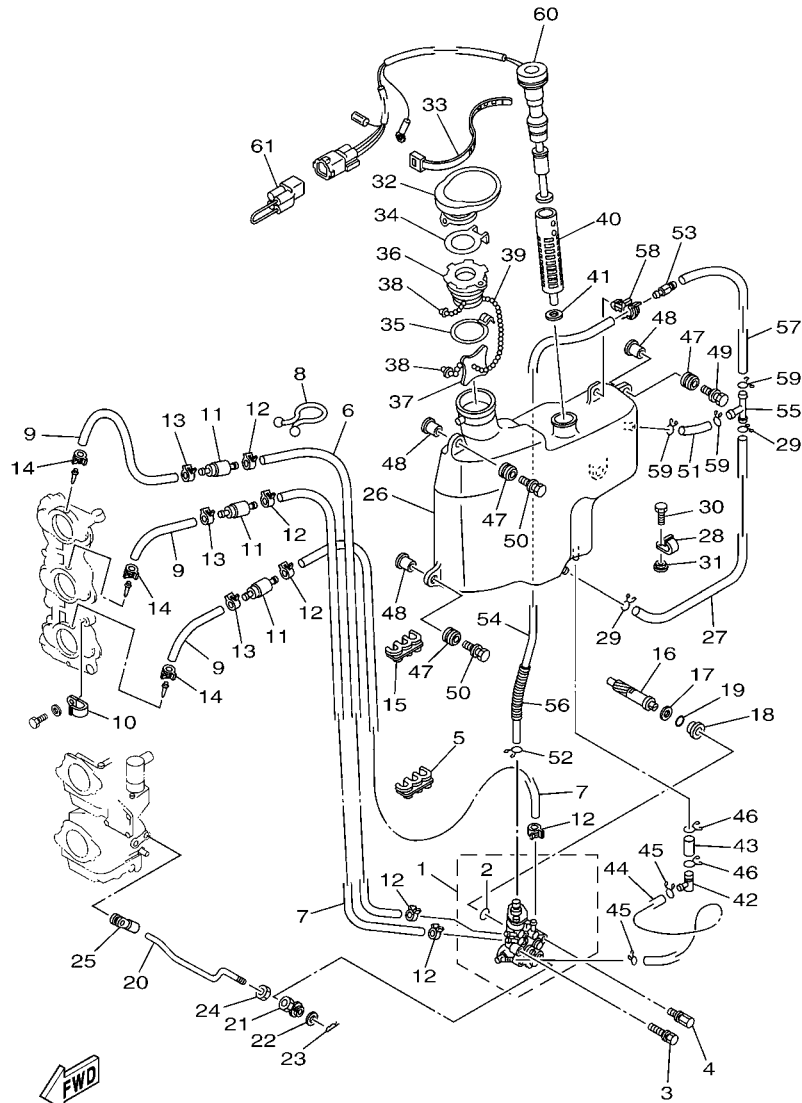

6H35100-E080

FIG. 8 OIL PUMP

BOMBA DE ACEITE

REF. NO.	PART NO. CODIGO Nº	DESCRIPTION DESCRIPCION	ET	ETO	REMARKS OBSERVACIONES
55	6E5-24378-00	PIPE, JOINT 3 TUBO DE UNION 3		1	
56	90446-10M01	HOSE (L60) TUBO (L60)		1	
57	90445-11M02	HOSE (L100) TUBO (L100)		1	
58	90464-11M23	CLAMP BRIDA		1	
59	90467-11M08	CLIP PRESILLA		3	
60	6H3-85720-17	OIL LEVEL GAUGE ASSY MEDIDOR DE NIVEL DE ACEITE		1	
61	6R5-82582-B0	COVER, WIRE HARNESS CUBIERTA DE ARNES DE CABLE		1	AP AP

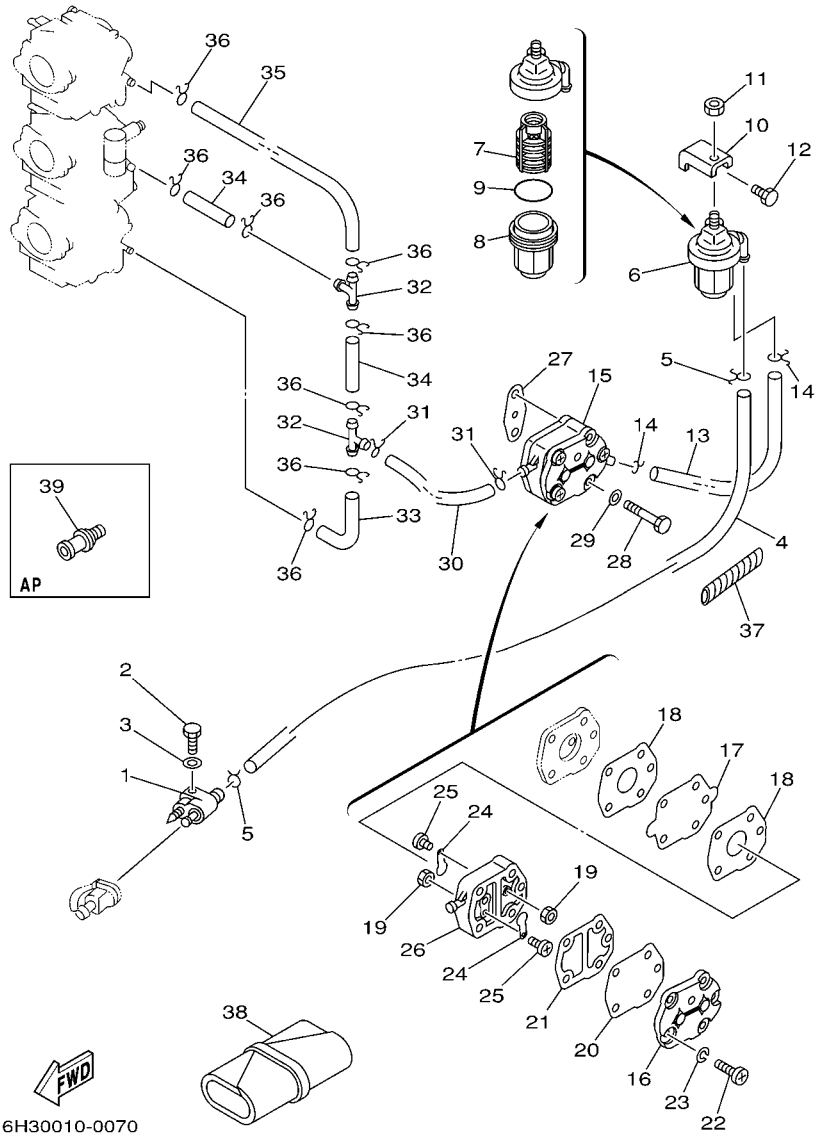

6H30010-0070

FIG. 9 FUEL COMBUSTIBLE

REF. NO.	PART NO. CODIGO Nº	DESCRIPTION DESCRIPCION	ET	E/O	REMARKS OBSERVACIONES
1	6G1-24304-02	FUEL PIPE JOINT COMP. 1 CONECTOR MANGUERA COMBUST.1	1	1	
2	97095-06025	BOLT PERNO	1	1	
3	92995-06600	WASHER ARANDELA	1	1	
4	90445-09M75	HOSE (L370) TUBO (L370)	1	1	
5	90467-08004	CLIP PRESILLA	2	2	
6	61N-24560-00	FILTER ASSY FILTRO COMPLETO	1	1	
7	61N-24563-00	.ELEMENT, FILTER .ELEMENTO DEL FILTRO	1	1	
8	61N-24521-00	.CUP, FILTER .COPA DE FILTRO	1	1	
9	93210-32738	.O-RING .ANILLO O	1	1	
10	648-24566-02	BRACKET, FILTER SOPORTE DEL FILTRO	1	1	
11	95380-08600	NUT TUERCA	1	1	
12	97013-06014	BOLT PERNO	1	1	
13	90445-09072	HOSE (L120) TUBO (L120)	1	1	
14	90467-08004	CLIP PRESILLA	2	2	
15	692-24410-00	FUEL PUMP ASSY BOMBA DE COMBUSTIBLE COMPLETA	1	1	
16	6A0-24413-00	.BODY 2 .CUERPO 2	1	1	
17	692-24411-00	.DIAPHRAGM .DIAFRAGMA	1	1	
18	648-24434-01	.GASKET, BODY .EMPAQUE	2	2	
19	95380-03600	.NUT .TUERCA	2	2	
20	663-24411-00	.DIAPHRAGM .DIAFRAGMA	1	1	
21	648-24435-02	.GASKET, BODY 2 .EMPAQUE	1	1	
22	98503-05028	.SCREW, PAN HEAD .TORNILLO DE CABEZA DE CONO ACH	3	3	
23	92990-05100	.WASHER, SPRING .ARANDELA PLANA	3	3	
24	6A0-24421-01	.VALVE, CHECK .VALVULA DE RETENCION	2	2	
25	6A0-14325-00	.SCREW, PAN HEAD .TORNILLO CABEZA REDONDA	2	2	
26	6A0-24412-02	.BODY 1 .CUERPO 1	1	1	
27	650-24431-A0	GASKET, FUEL PUMP 1 EMPAQUE BOMBA COMBUST 1	1	1	

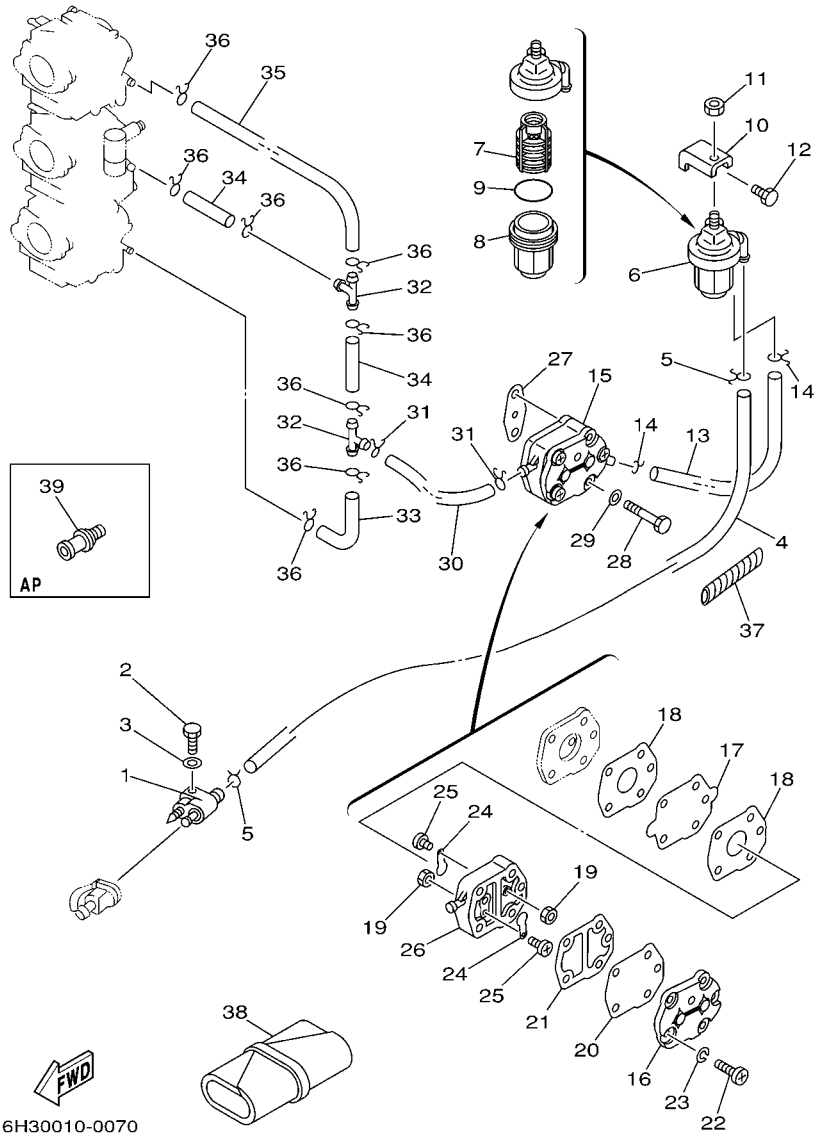
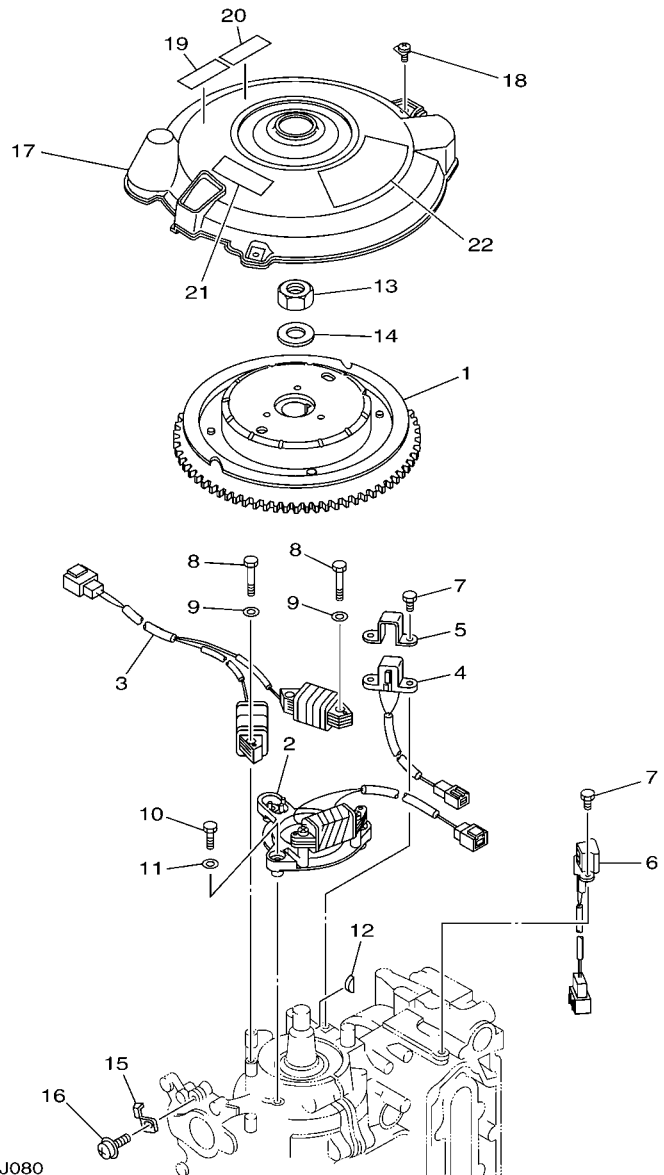

FIG. 9 FUEL

COMBUSTIBLE

REF. NO.	PART NO. CODIGO Nº	DESCRIPTION DESCRIPCION	ET	EYO	REMARKS OBSERVACIONES
28	97095-06040	BOLT PERNO	2	2	
29	92995-06600	WASHER ARANDELA	2	2	
30	90445-09072	HOSE (L120) TUBO (L120)	1	1	
31	90467-08004	CLIP PRESILLA	2	2	
32	688-24378-00	PIPE, JOINT 3 TUBO DE UNION 3	2	2	
33	6H3-24313-00	PIPE 3 TUBO 3	1	1	
34	90445-09220	HOSE (L30) TUBO (L30)	2	2	
35	6H3-24314-00	PIPE 4 TUBO 4	1	1	
36	90467-08004	CLIP PRESILLA	8	8	
37	90446-10M01	HOSE (L60) TUBO (L60)	1	1	60F,70B-O/I 60F,70B-O/I
38	656-W2810-02	TOOL KIT JUEGO DE HERRAMIENTAS	1	1	
39	6E0-28193-00	PLUG, WATER CHECK TAPON DE CONTROL DE LA AGUA	1	1	AP D:12.5MM AP D:12.5MM



6H39300-J080

FIG. 10 GENERATOR

GENERADOR

REF. NO.	PART NO. CODIGO Nº	DESCRIPTION DESCRIPCION	ET	EPO		REMARKS OBSERVACIONES
1	6H2-85550-01	ROTOR ASSY ROTOR COMPLETO	1	1		
2	6H2-85520-02	COIL, CHARGE BOBINA DE CARGA	1	1		
3	6H2-85533-01	COIL, LIGHTING BOBINA DE LUZ	1	1		
4	6H2-85580-01	COIL, PULSER BOBINA DE PULSACION	1	1		
5	6H2-85582-00	ATTACHMENT, PULSER SOPORTE DE PULSACION	1	1		
6	6H2-85895-01	CRANK POSITION SENDER SENSOR, POSICION DE CIGUENAL	1	1		
7	97095-05012	BOLT PERNO	4	4		
8	97095-06035	BOLT PERNO	4	4		
9	92995-06600	WASHER ARANDELA	4	4		
10	97095-06025	BOLT PERNO	3	3		
11	92995-06600	WASHER ARANDELA	3	3		
12	90280-05015	KEY, WOODRUFF CUNA WOODRUFF	1	1		
13	90170-20137	NUT TUERCA	1	1		
14	90201-21M18	WASHER, PLATE ARANDELA PLANA	1	1		
15	6E5-81332-00	PLATE, TIMING PLACA REGULADOR DE TIEMPO	1	1		
16	97985-06210	SCREW, WITH WASHER TORNILLO, CON ARANDELA	1	1		
17	6H3-81337-01	COVER, FLYWHEEL CUBIERTA DE VOLANTE	1	1		
18	90159-06M23	SCREW, WITH WASHER TORNILLO CON VALONA	3	3		
19	6EE-81995-40	LABEL, WARNING ETIQUETA DE PRECAUCION	1	1		EXCEPT FOR BRA
	6AH-81995-70	LABEL, WARNING ETIQUETA DE PRECAUCION	1	1		FOR BRA
	6EE-81995-50	LABEL, WARNING ETIQUETA DE PRECAUCION	1	1		FOR BRA
20	6EE-81995-50	LABEL, WARNING ETIQUETA DE PRECAUCION	1	1		FOR RUS
						FOR RUS
21	6AG-81996-00	MARK MARCA	1	1		FOR RUS,CAR(CE)
						FOR RUS,CAR(CE)
22	6H3-13437-21	MARK, CAUTION MARKER	1	1		EXCEPT FOR BRA
						EXCEPT FOR BRA



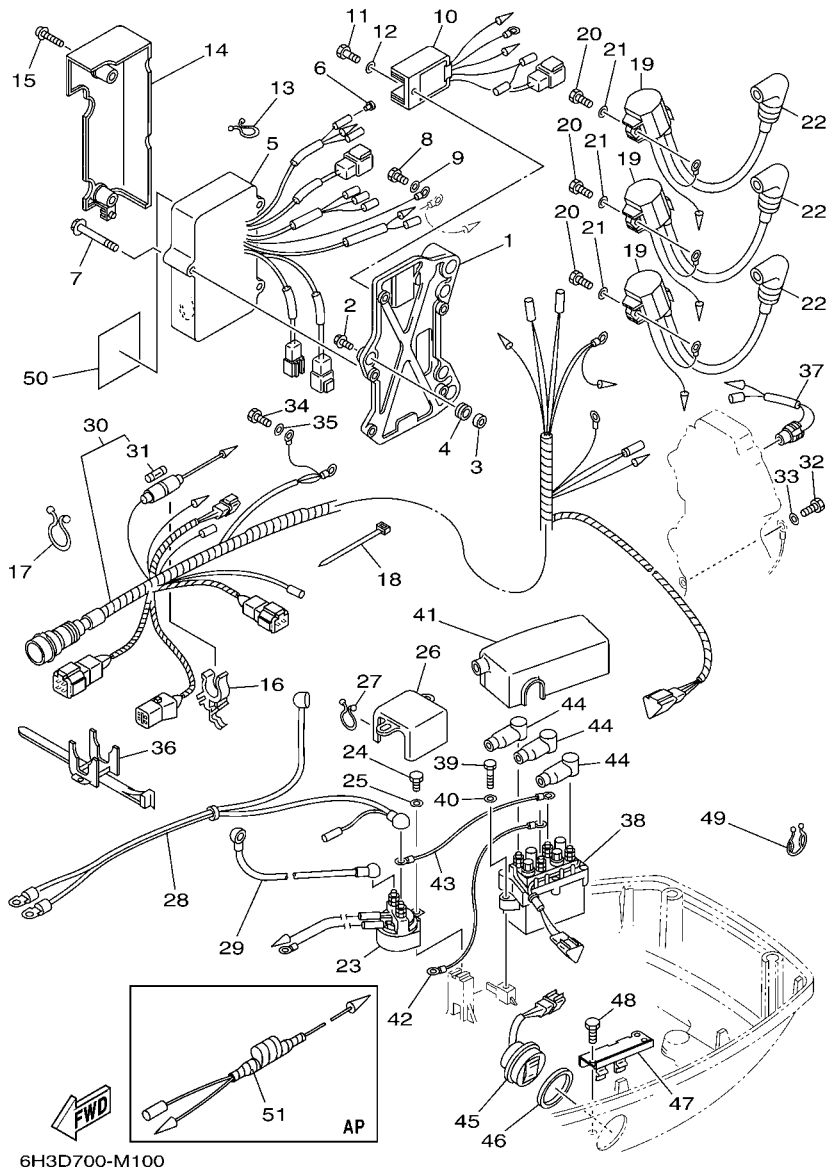

6H3D700-M100

FIG. 11 ELECTRICAL

ELECTRICO

REF. NO.	PART NO. CODIGO Nº	DESCRIPTION DESCRIPCION	ET	E/O	REMARKS OBSERVACIONES
1	6H3-85542-11	BRACKET SOPORTE	1	1	
2	90105-06M14	BOLT FLANGE TORNILLO	3	3	
3	90387-06M43	COLLAR ESPACIADOR	3	3	
4	90480-13M54	GROMMET TAPON	3	3	
5	6H2-85540-13	C.D.I. UNIT ASSY UNIDAD C.D.I. COMPLETA	1	1	
6	703-82119-00	COVER, LEAD WIRE CUBIERTA DE CABLE CONDUCTOR	1	1	
7	97595-06545	BOLT, WITH WASHER PERNO CON ARANDELA	3	3	
8	97013-06012	BOLT PERNO	1	1	
9	92903-06600	WASHER, PLATE RONDANA SENCILLA	1	1	
10	6H2-81960-10	RECTIFIER & REGULATOR ASSY RECTIFICADOR Y REGULADOR	1	1	
11	97095-06016	BOLT PERNO	1	1	
12	92995-06600	WASHER ARANDELA	1	1	
13	90464-05M16	CLAMP BRIDA	1	1	
14	6H3-81916-10	COVER, TERMINAL CUBIERTA DE TERMINAL	1	1	
15	90159-06M01	SCREW, WITH WASHER TORNILLO CON VALONA	2	2	
16	6G5-82152-00	HOLDER, FUSE PORTA-FUSIBLES	1	1	
17	90464-23M22	CLAMP BRIDA	1	1	
18	90465-13M11	CLAMP BRIDA	1	1	
19	697-85570-00	IGNITION COIL ASSY BOBINA DE IGNICION COMPLETO	3	3	
20	97013-06020	BOLT PERNO	3	3	
21	92903-06600	WASHER, PLATE RONDANA SENCILLA	3	3	
22	6G1-82370-21	PLUG CAP ASSY TAPON DE BUJIA COMPLT	3	3	
23	688-81950-10	RELAY ASSY RELE COMPLETO	1	1	
24	97013-06016	BOLT PERNO	1	1	
25	92903-06600	WASHER, PLATE RONDANA SENCILLA	1	1	
26	6H3-82164-00	CASE 2 BUJE	1	1	
27	90464-15M11	CLAMP BRIDA	1	1	

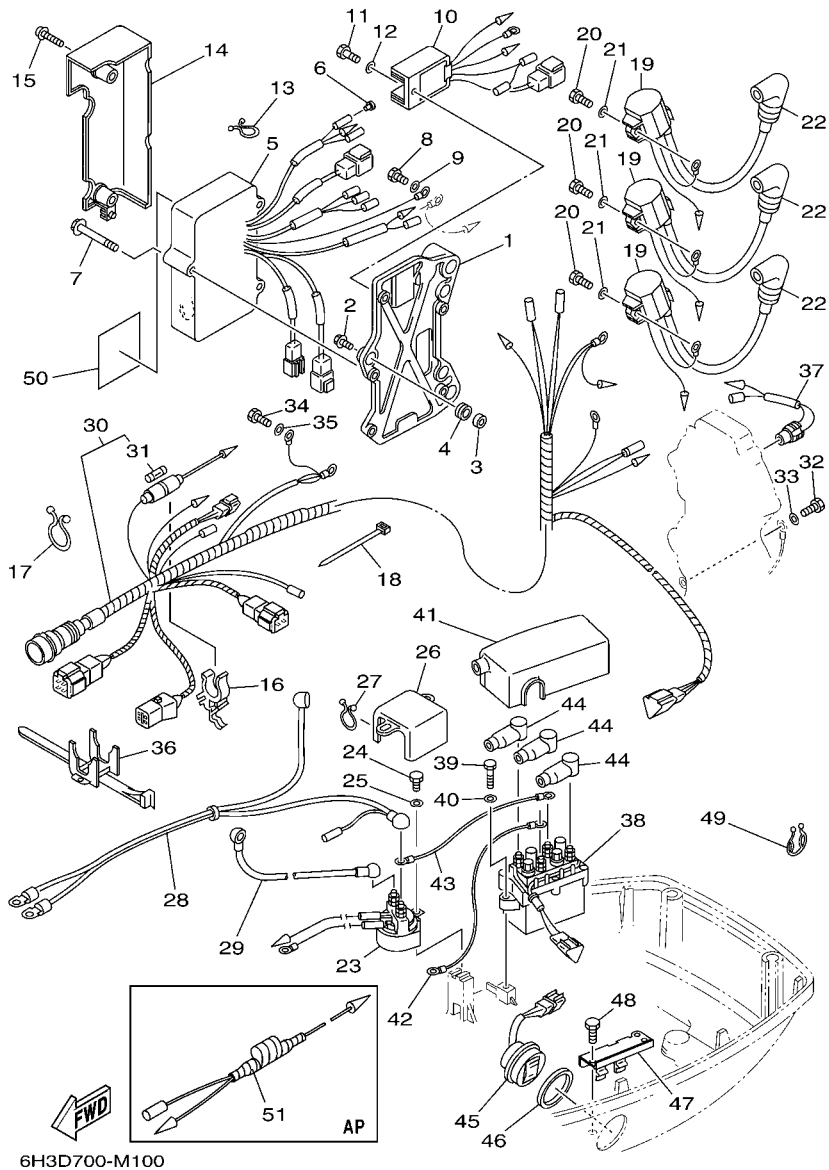

FIG. 11 ELECTRICAL

ELECTRICO

REF. NO.	PART NO. CODIGO Nº	DESCRIPTION DESCRIPCION	ET	E/O	REMARKS OBSERVACIONES
28	6H3-82105-02	BATTERY CABLE CABLE DE BATERIA	1	1	
29	6H3-82117-00	WIRE, LEAD CABLE CONDUCTOR	1	1	
30	6H2-82590-13	WIRE HARNESS ASSY (10P) CONJUNTO DE CABLES (10P)	1		
	6H2-82590-80	WIRE HARNESS ASSY (10P) CONJUNTO DE CABLES (10P)		1	
31	663-82151-00	.FUSE (12V-20A) .FUSIBLE (12V-20A)	1	1	
32	97013-06012	BOLT PERNO	1	1	
33	92903-06600	WASHER, PLATE RONDANA SENCILLA	1	1	
34	97013-06012	BOLT PERNO	2	2	
35	92903-06600	WASHER, PLATE RONDANA SENCILLA	2	2	
36	688-82594-00	CLAMP GRAMPA	1	1	
37	688-82560-10	THERMO SWITCH ASSY INTER. DE TERMO	1	1	
38	61A-81950-00	RELAY ASSY RELE COMPLETO	1	1	
39	97095-06025	BOLT PERNO	2	2	
40	92995-06600	WASHER ARANDELA	2	2	
41	6H3-82154-11	CASE CAJA	1	1	
42	6H2-81949-11	WIRE, LEAD CABLE CONDUCTOR	1	1	
43	6H2-81949-01	WIRE, LEAD CABLE CONDUCTOR	1	1	
44	682-82119-01	COVER, LEAD WIRE CUBIERTA DE CABLE CONDUCTOR	3	3	
45	6H1-82563-11	TRIM & TILT SWITCH ASSY INTERRUPTOR DE INCLINACION	1	1	
46	6E5-82587-00	GASKET EMPAQUETADURA	1	1	
47	6E5-83614-01	BRACKET SOPORTE	1	1	
48	97095-06016	BOLT PERNO	2	2	
49	90464-18M14	CLAMP BRIDA	1	1	
50	6R5-85711-60	MARK, CAUTION MARKER	1	1	
51	6H4-81315-11	LEAD WIRE ASSY CABLE CONDUCTOR COMPLETO		1	AP AP

FIG. 12 STARTING MOTOR

MOTOR DE ARRANQUE

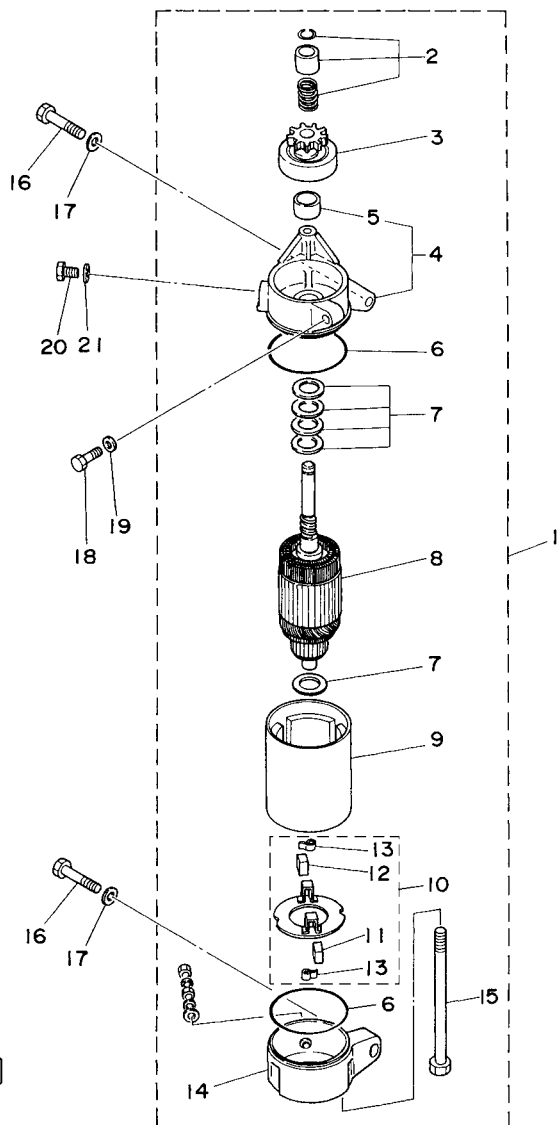

69D3200-C140

REF. NO.	PART NO. CODIGO Nº	DESCRIPTION DESCRIPCION	ET	EPO	REMARKS OBSERVACIONES
1	6H3-81800-11	STARTING MOTOR ASSY MOTOR DE ARRANQUE COMPLETO	1	1	
2	689-81857-11	.PINION STOPPER SET .JUEGO TAPON PINON	1	1	
3	6H3-81807-10	.GEAR ASSY, STARTING MOTOR .PINON CONJUNTO	1	1	
4	6H3-81830-10	.FRONT BRACKET ASSY .SOPORTE DELANTERO COMPLETO	1	1	
5	689-81831-00	..METAL, FRONT ..METAL, DELANTERO	1	1	
6	689-81847-11	.O-RING .ANILLO GOMA	2	2	
7	689-81809-11	.WASHER KIT .JUEGO DE ARANDELA	1	1	
8	689-81850-12	.ARMATURE ASSY .INDUCIDO COMPLETO	1	1	
9	6H3-81810-10	.STATOR ASSY .ESTATOR COMPLETO	1	1	
10	689-81840-11	.BRUSH HOLDER ASSY .SOSTEN DE ESCOBILLA COMPLETO	1	1	
11	689-81812-11	..BRUSH 2 ..ESCOBILLA 2	1	1	
12	689-81811-11	..BRUSH 1 ..ESCOBILLA 1	1	1	
13	689-81813-10	..SPRING, BRUSH ..RESORTE DE ESCOBILLA	2	2	
14	6H3-81820-11	.REAR BRACKET ASSY .CUBIERTA TRASERA COMPL	1	1	
15	689-81826-10	.BOLT .PERNO	2	2	
16	97013-08035	BOLT PERNO	2	2	
17	92903-08600	WASHER, PLATE RONDANA SENCILLA	2	2	
18	97013-06025	BOLT PERNO	1	1	
19	92903-06600	WASHER, PLATE RONDANA SENCILLA	1	1	
20	97013-08016	BOLT PERNO	1	1	
21	92903-08600	WASHER, PLATE RONDANA SENCILLA	1	1	

FIG. 13 BOTTOM COWLING

CUBIERTA INFERIOR

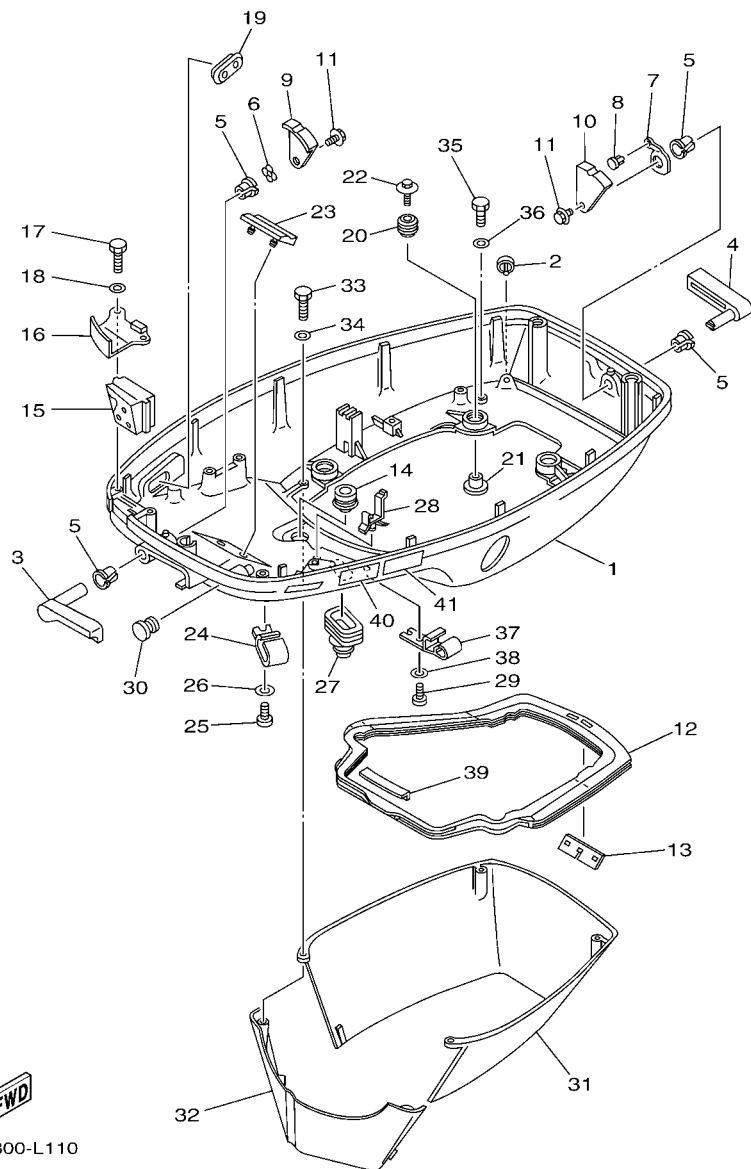

6H3B300-L110

REF. NO.	PART NO. CODIGO Nº	DESCRIPTION DESCRIPCION	ET	EIO	REMARKS OBSERVACIONES
1	6H3-42711-25-4D	COWLING, BOTTOM 1 CUBIERTA INFERIOR 1	1	1	
2	69D-44391-00	NIPPLE, HOSE NIPLE MANGUERA	1	1	L(20.5") L(20.5")
3	6H3-42815-01-4D	LEVER, CLAMP PALANCA ABRAZADERA	1	1	
4	6H3-42817-01-4D	LEVER, CLAMP PALANCA ABRAZADERA	1	1	
5	90386-13M38	BUSH BUJE	4	4	
6	90206-13M10	WASHER, WAVE ARANDELA ONDULADA	1	1	
7	6H3-42813-00	SPRING, CLAMP LEVER RESORTE	1	1	
8	90269-04M03	RIVET REMACHE	1	1	
9	6H3-42816-00	LEVER, CLAMP PALANCA ABRAZADERA	1	1	
10	6H3-42818-00	LEVER, CLAMP PALANCA, ABRAZADERA	1	1	
11	90119-06M09	BOLT, WITH WASHER TORNILLO CON ARANDELA	2	2	
12	6H3-42716-02	RUBBER, SEAL 1 SELLO DE GOMA 1	1	1	
13	6K5-42717-00	RUBBER, SEAL 2 GOMA	1	1	
14	6E5-42724-00	GROMMET TAPON	1	1	
15	6H3-42725-10	GROMMET TAPON	1	1	60F,70B 60F,70B
	6H3-42725-30	GROMMET TAPON	1	1	60F 60F
16	6H3-42738-01-CA	PLATE, FITTING PLACA DE AJUSTE	1	1	
17	97095-06016	BOLT PERNO	2	2	
18	92995-06600	WASHER ARANDELA	2	2	
19	6H3-42727-00	GROMMET TAPON	1	1	
20	6BG-42748-00	GROMMET TAPON	4	4	
21	90387-06M69	COLLAR ESPACIADOR	4	4	
22	90119-06M61	BOLT, WITH WASHER TORNILLO CON ARANDELA	4	4	
23	6H3-42768-00	DAMPER AMORTIGUADOR	1	1	
24	6E5-24367-01	CLAMP, FUEL PIPE 2 GRAMPA DE TUBO DE COMBUST.2	1	1	
25	90157-06M01	SCREW, PAN HEAD TORNILLO CABEZA CONICA PLANA	1	1	
26	92990-06600	WASHER, PLATE ARANDELA PLANA	1	1	

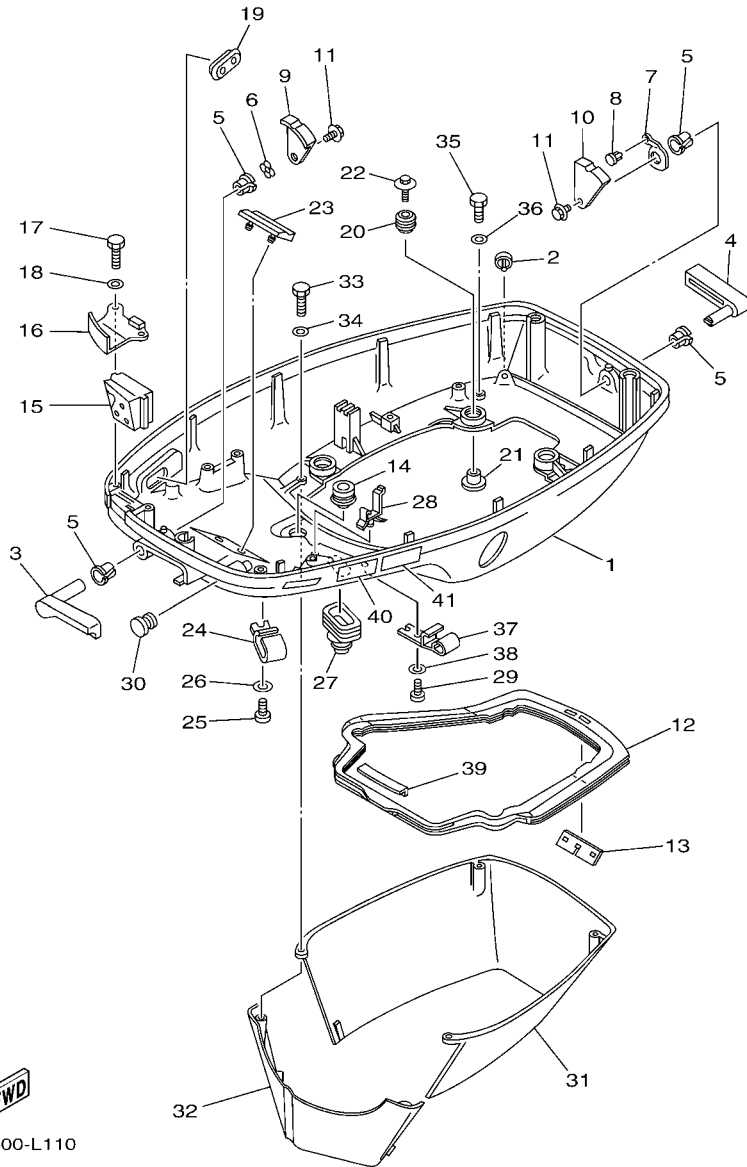

  
 6H3B300-L110

FIG. 13 BOTTOM COWLING

CUBIERTA INFERIOR

REF. NO.	PART NO. CODIGO Nº	DESCRIPTION DESCRIPCION	ET	EYO		REMARKS OBSERVACIONES
27	688-42726-10	GROMMET TAPON	1	1		
28	90464-16021	CLAMP BRIDA	1	1		
29	90157-06M01	SCREW, PAN HEAD TORNILLO CABEZA CONICA PLANA	1	1		
30	6G1-42748-00	GROMMET TAPON	1	1		
31	6H3-42741-01-4D	APRON MANDIL	1	1		
32	6H3-42771-01-4D	APRON MANDIL	1	1		
33	97095-06025	BOLT PERNO	2	2		
34	92995-06600	WASHER ARANDELA	2	2		
35	97095-06020	BOLT PERNO	2	2		
36	92995-06600	WASHER ARANDELA	2	2		
37	6E5-24367-01	CLAMP, FUEL PIPE 2 GRAMPA DE TUBO DE COMBUST.2	1	1		
38	92990-06600	WASHER, PLATE ARANDELA PLANA	1	1		
39	6H3-42718-00	RUBBER, SEAL 3 GOMA	1	1		
40	6EE-42794-40	LABEL, WARNING (GENERAL) ETIQUETA DE PRECAUCION	1	1		EXCEPT FOR BRA EXCEPT FOR BRA
	6AH-42794-70	LABEL, WARNING (GENERAL) ETIQUETA DE PRECAUCION		1		FOR BRA FOR BRA
41	6EE-42794-50	LABEL, WARNING (GENERAL) ETIQUETA DE PRECAUCION		1		FOR RUS FOR RUS

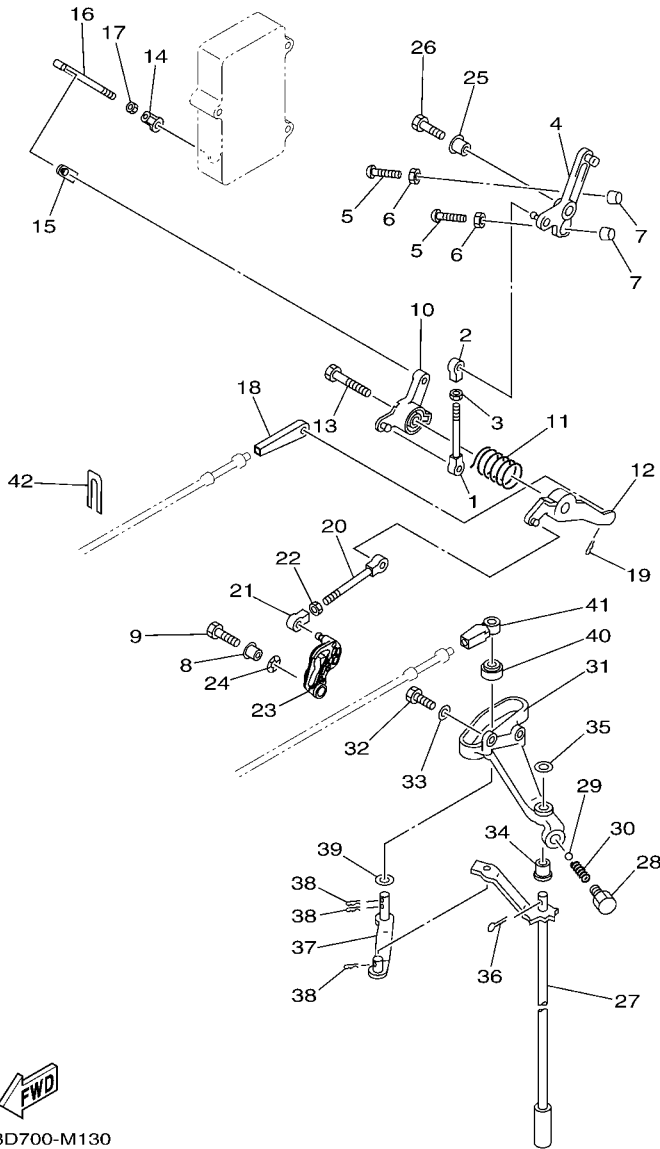

6H3D700-M130

FIG. 14 CONTROL

CONTROL

REF. NO.	PART NO. CODIGO Nº	DESCRIPTION DESCRIPCION	ET	EPO		REMARKS OBSERVACIONES
1	689-42169-01	JOINT CONECTOR	1	1		
2	682-41237-00	JOINT, LINK CONECTOR	1	1		
3	95380-05600	NUT TUERCA	1	1		
4	6H3-41631-00	LEVER, MAGNETO CONTROL PALANCA DE CONTROL DE MAGNETO	1	1		
5	90157-06M13	SCREW, PAN HEAD TORNILLO CABEZA CONICA PLANA	2	2		
6	95380-06600	NUT, HEXAGON TUERCA	2	2		
7	688-44194-00	CAP TAPA	2	2		
8	90387-06289	COLLAR ESPACIADOR	1	1		
9	97095-06025	BOLT PERNO	1	1		
10	6H3-41632-20	LEVER, MAGNETO CONTROL PALANCA DE CONTROL DE MAGNETO	1	1		
11	90508-26M35	SPRING, TORSION RESORTE DE TORSION	1	1		
12	6H3-41633-10	LEVER, MAGNETO CONTROL PALANCA DE CONTROL DE MAGNETO	1	1		
13	90109-06M43	BOLT PERNO	1	1		
14	6H1-41237-00	JOINT, LINK CONECTOR	1	1		
15	6F5-41237-00	JOINT, LINK CONECTOR	1	1		
16	6H3-41636-10	ROD, MAGNETO CONTROL VARILLA DE CONTROL MAGNETO	1	1		
17	95380-05600	NUT TUERCA	1	1		
18	6H3-48344-00	CABLE END, REMOTE CONTROL BASE CONTROL	1	1		
19	90468-18008	CLIP PRESILLA	1	1		
20	689-42169-01	JOINT CONECTOR	1	1		
21	6H4-41237-00	JOINT, LINK CONECTOR	1	1		
22	95380-05600	NUT TUERCA	1	1		
23	6H3-41213-30	CAM, ACCEL. LEVA ACELERADOR	1	1		
24	90206-10M04	WASHER, WAVE ARANDELA ONDULADA	1	1		
25	90387-06289	COLLAR ESPACIADOR	1	1		
26	97095-06025	BOLT PERNO	1	1		
27	6H3-44120-13	HANDLE GEAR SHIFT ASSY MANIJA DE CAMBIO COMPL	1	1		L(20.5") L(20.5")

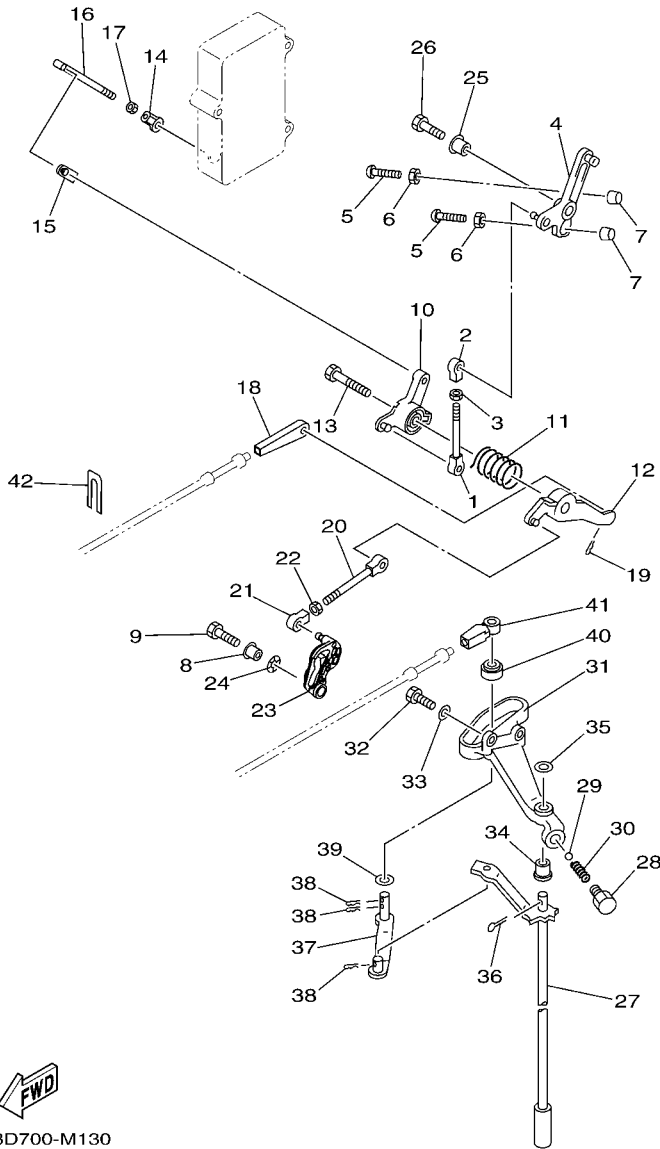

6H3D700-M130

FIG. 14 CONTROL

CONTROL

REF. NO.	PART NO. CODIGO Nº	DESCRIPTION DESCRIPCION	ET	EYO	REMARKS OBSERVACIONES
28	648-42715-00	BUSHING BUJE	1	1	
29	93501-04M02	BALL BOLA	1	1	
30	90501-12082	SPRING, COMPRESSION RESORTE DE COMPRESION	1	1	
31	6H3-44117-00-94	BRACKET SOPORTE	1	1	
32	97013-06020	BOLT PERNO	2	2	
33	92903-06600	WASHER, PLATE RONDANA SENCILLA	2	2	
34	90386-07M58	BUSH BUJE	1	1	
35	92990-08200	WASHER, PLAIN ARANDELA PLANA	1	1	
36	91490-20012	PIN, COTTER CHAVETA	1	1	
37	6H3-44121-01	LEVER, SHIFT ROD PALANCA VARILLA CAMBIOS	1	1	
38	90468-18008	CLIP PRESILLA	3	3	
39	90202-07M07	WASHER, PLATE ARANDELA DE PLANA	1	1	
40	688-44122-00	BUSHING, SHIFT ROD LEVER BUJE PALANCA VARILLA DE CAMBIO	1	1	
41	663-48344-00	CABLE END, REMOTE CONTROL BASE CONTROL	1	1	
42	6H3-48538-00	CLAMP, CABLE 1 GRAMPA DE CABLE	1	1	

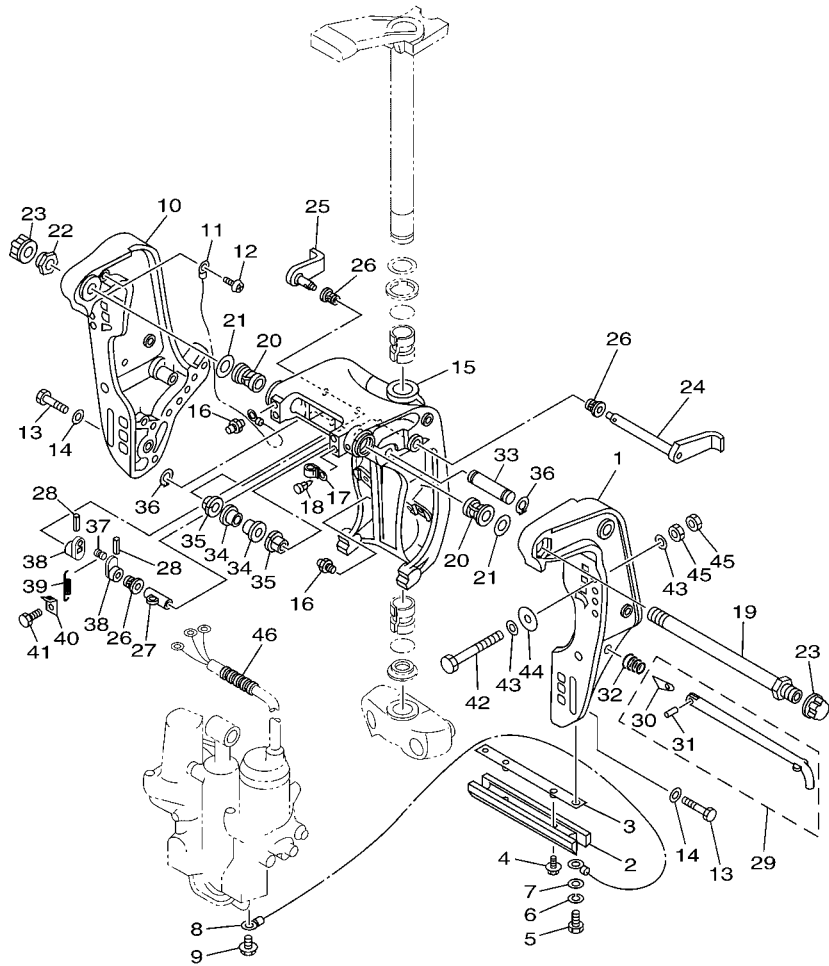

6H3D700-M140

FIG. 15 BRACKET 1

SOPORTE 1

REF. NO.	PART NO. CODIGO Nº	DESCRIPTION DESCRIPCION	ET	E/O		REMARKS OBSERVACIONES
1	6H1-43111-01-4D	BRACKET, CLAMP 1 SOPORTE DE LA ABRAZADERA 1	1	1		
2	6H1-45251-03	ANODE CATODE	1	1		
3	6EK-44536-00	PLATE 2 PLACA 2	1	1		
4	90119-06M29	BOLT, WITH WASHER TORNILLO CON ARANDELA	2	2		
5	97095-06016	BOLT PERNO	2	2		
6	92995-06100	WASHER, SPRING ARANDELA	2	2		
7	92995-06600	WASHER ARANDELA	2	2		
8	6H1-82148-00	WIRE, LEAD 4 CABLE CONDUCTOR 4	1	1		
9	97595-06510	BOLT, WITH WASHER PERNO CON ARANDELA	1	1		
10	6H1-43112-00-4D	BRACKET, CLAMP 2 SOPORTE DE LA ABRAZADERA 2	1	1		
11	6E5-82148-00	WIRE, LEAD 4 CABLE CONDUCTOR 4	1	1		
12	97880-06012	SCREW, PAN HEAD TORNILLO DE CABEZA CON PLANA	1	1		
13	97095-10045	BOLT PERNO	6	6		
14	92995-10600	WASHER ARANDELA	6	6		
15	6H1-43311-02-4D	BRACKET, SWIVEL 1 SOPORTE GIRATORIO 1	1	1		
16	93700-06M03	NIPPLE, GREASE BOQUILLA DE ENGRASAR	3	3		
17	90464-11M18	CLAMP BRIDA	1	1		
18	90338-05M03	PLUG TAPON	1	1		
19	688-43131-03	BOLT, CLAMP BRACKET TORNILLO DE ABRAZADERA DEL SOP	1	1		
20	90386-22M15	BUSH BUJE	2	2		
21	90201-22M67	WASHER, PLATE ARANDELA PLANA	2	2		
22	90185-22043	NUT, SELF-LOCKING TUERCA AUTOBLOCANTE	1	1		
23	6G5-43145-01	CAP, CLAMP BRACKET TAPA	2	2		
24	6H1-43181-01	LEVER, TILT STOP 1 PALANCA TOPE INCLINACION 1	1	1		
25	6H1-43185-01	LEVER, TILT STOP 2 PALANCA TOPE INCLINACION 2	1	1		
26	90386-10M16	BUSH BUJE	3	3		
27	90387-10M02	COLLAR ESPACIADOR	1	1		



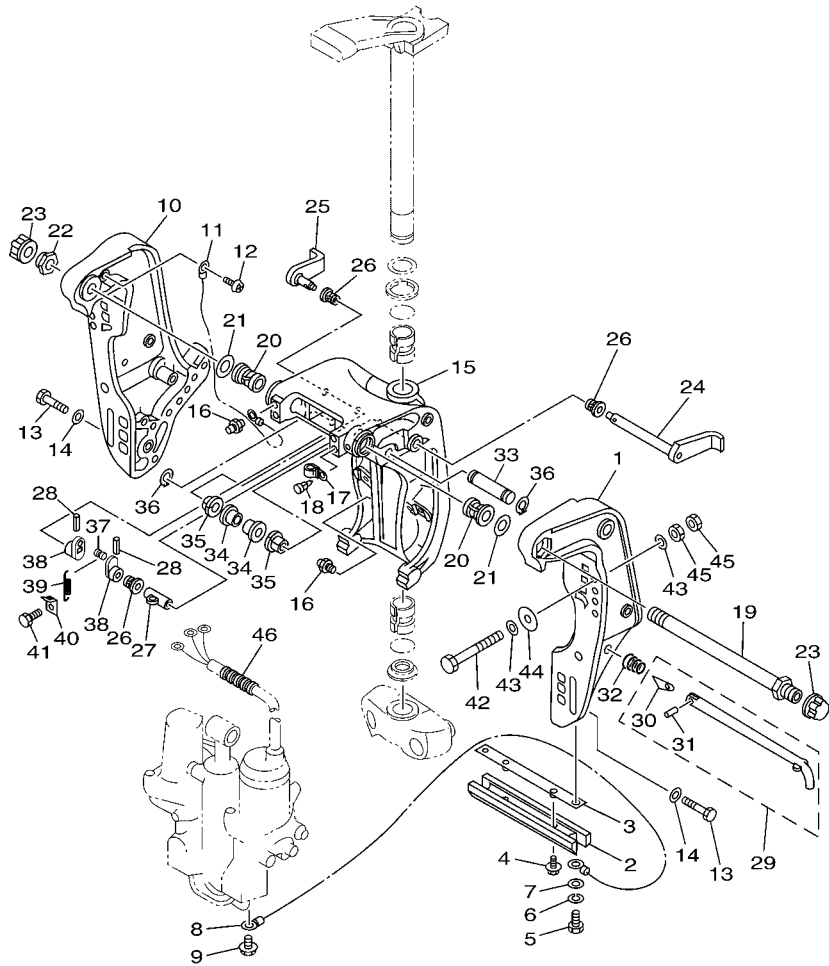

  
 6H3D700-M140

FIG. 15 BRACKET 1

SOPORTE 1

REF. NO.	PART NO. CODIGO Nº	DESCRIPTION DESCRIPCION	ET	EPO	REMARKS OBSERVACIONES
28	91690-30020	PIN, SPRING PASADOR DE RESORTE	2	2	
29	688-43160-01	TILT ROD ASSY VARILLA DE BASCULACION COMPL.	1	1	
30	688-43165-00	.PLATE, TILT LOCK .PLACA DE TOPE, VARILLA SEGURID	1	1	
31	91690-30012	.PIN, SPRING .PASADOR DE RESORTE	1	1	
32	90502-16M02	SPRING, CONICAL RESORTE CONICO	1	1	
33	6E5-43126-10	PIN, UPPER SHOCK MOUNT PASADOR DE AMORTIGUADOR SUPERI	1	1	
34	90386-18M63	BUSH BUJE	2	2	
35	90386-18M35	BUSH BUJE	2	2	
36	93410-18M05	CIRCLIP SEGURO	2	2	
37	90249-06M19	PIN PASADOR	1	1	
38	6G5-43148-00	COLLAR, DISTANCE COLLAR	2	2	
39	90506-14M24	SPRING, TENSION RESORTE DE TENSION	1	1	
40	6G5-43144-00	HOOK, SPRING GANCHO	1	1	
41	97095-06010	BOLT PERNO	1	1	
42	90101-12M65	BOLT TORNILLO	4	4	
43	90201-12062	WASHER, PLATE ARANDELA PLANA	8	8	
44	90201-12426	WASHER, PLATE ARANDELA PLANA	4	4	
45	95380-12600	NUT TUERCA	8	8	
46	90440-14M00	PIPE TUBO	1	1	

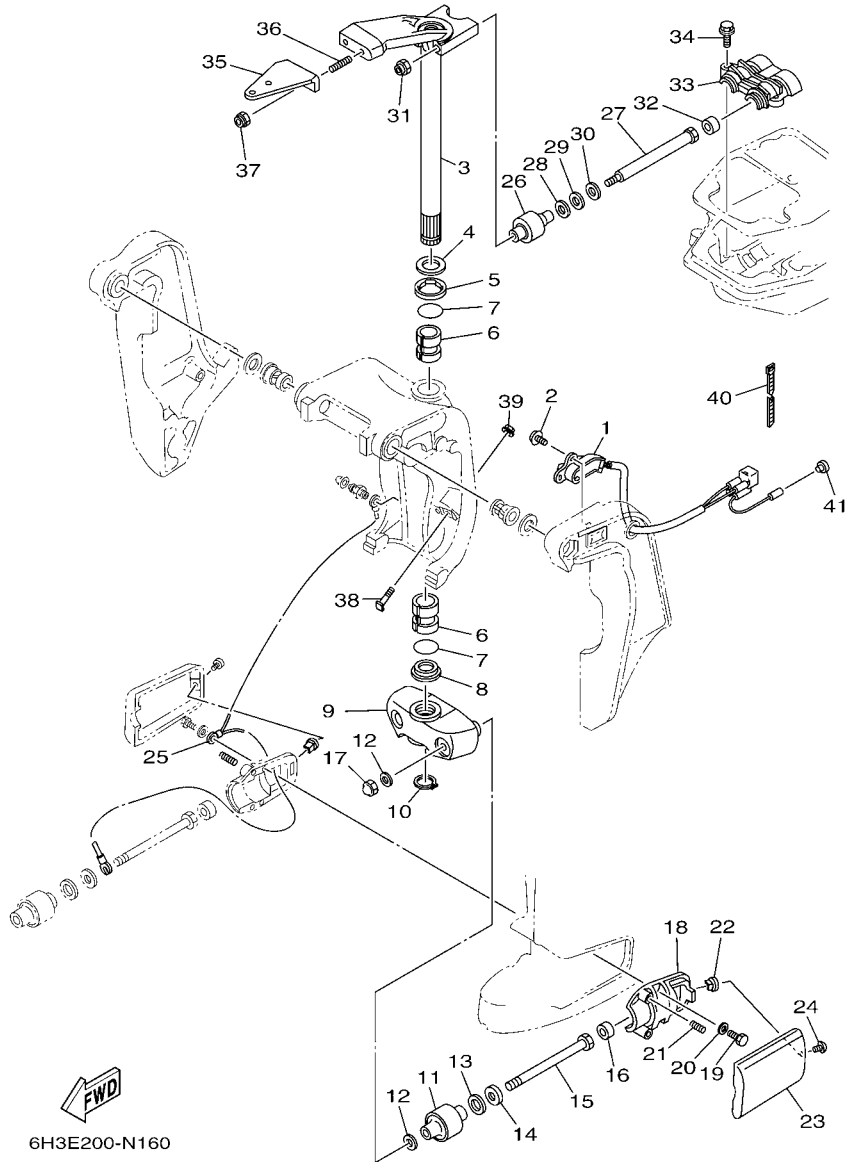

6H3E200-N160

FIG. 16 BRACKET 2

SOPORTE 2

REF. NO.	PART NO. CODIGO Nº	DESCRIPTION DESCRIPCION	ET	E/O		REMARKS OBSERVACIONES
1	6H1-83672-13	TRIM SENDER TRANSMISOR DE INCLINADOR	1			
	6H1-83672-21	TRIM SENDER TRANSMISOR DE INCLINADOR		1		
2	97985-06216	SCREW, WITH WASHER TORNILLO, CON ARANDELA	2	2		
3	6H3-42510-13-4D	STEERING BRACKET ASSY SOPORTE DIRECCION COMPL.	1	1		
4	90201-30M00	WASHER, PLATE ARANDELA PLANA	1	1		
5	90386-30M78	BUSH BUJE	1	1		
6	90386-30M77	BUSH BUJE	2	2		
7	93210-29M94	O-RING ANILLO O	2	2		
8	90386-30M60	BUSH BUJE	1	1		
9	6H3-44551-01-4D	HOUSING, LOWER MOUNT RUBBER 1 CAJA AMORTIGUADOR INFERIOR HU	1	1		
10	93410-28M06	CIRCLIP SEGURO	1	1		
11	687-44555-00	MOUNT DAMPER, LOWER SIDE AMORTIGUADOR DE HULE LADO INFE	2	2		
12	90201-12M16	WASHER, PLATE ARANDELA PLANA	4	4		
13	90202-25M04	WASHER, PLATE ARANDELA DE PLANA	2	2		
14	90201-13M19	WASHER, PLATE ARANDELA PLANA	2	2		
15	90109-12M21	BOLT PERNO	2	2		
16	663-44575-00	DAMPER, LOWER MOUNT RUBBER AMORTIGUADOR INFERIOR	2	2		
17	95380-12800	NUT, CROWN TUERCA	2	2		
18	6H3-44552-03	HOUSING, LOWER MOUNT RUBBER 2 CAJA AMORTIGUADOR INFERIOR HU	2	2		
19	97075-08025	BOLT PERNO	4	4		
20	92995-08600	WASHER ARANDELA	4	4		
21	90501-14M08	SPRING, COMPRESSION RESORTE DE COMPRESION	4	4		
22	90179-06066	NUT TUERCA	2	2		
23	6H3-44553-01-4D	COVER, LOWER MOUNT CUBIERTA, AMORTIGUADOR INFERIOR	2	2		
24	97885-06016	SCREW, PAN HEAD TORNILLO A MUESCA	2	2		
25	688-82127-02	WIRE, LEAD 2 CABLE CONDUCTOR 2	1	1		
26	688-44514-00	MOUNT DAMPER, UPPER SIDE AMORTIGUADOR LADO SUPERIOR	2	2		

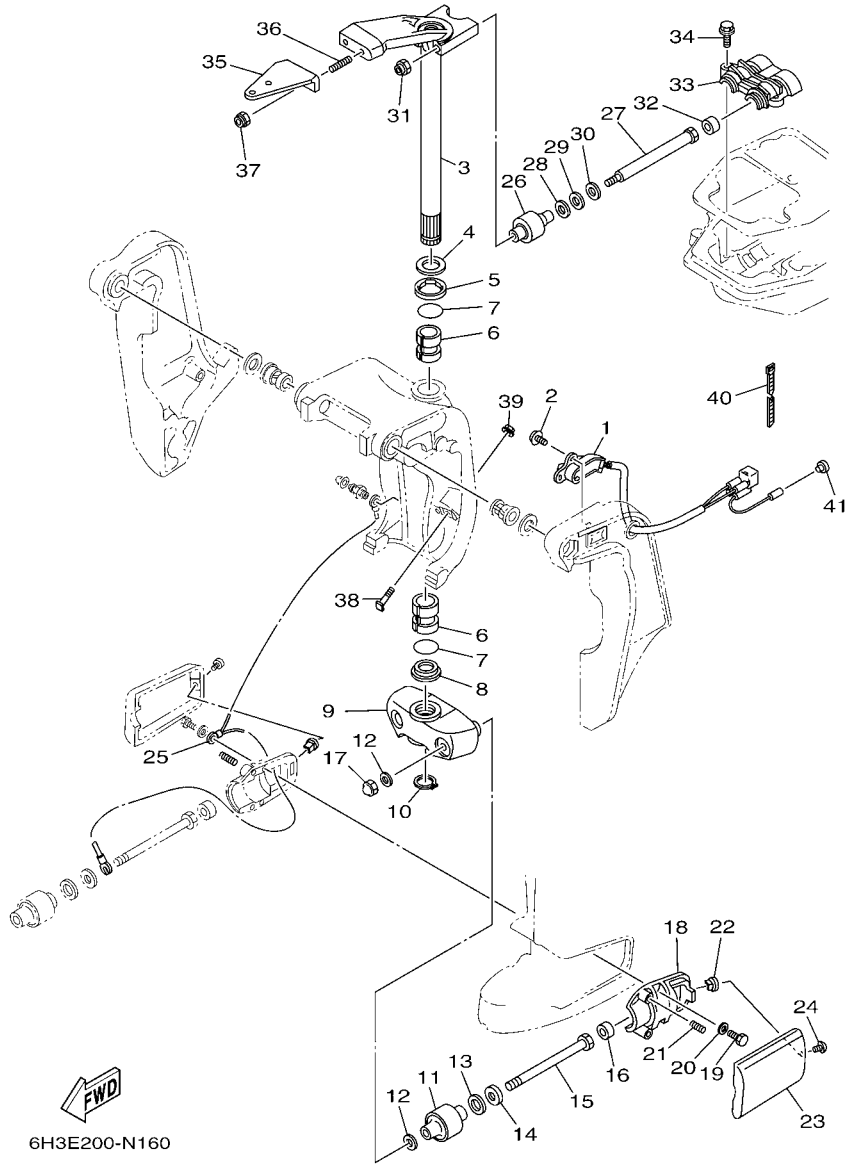
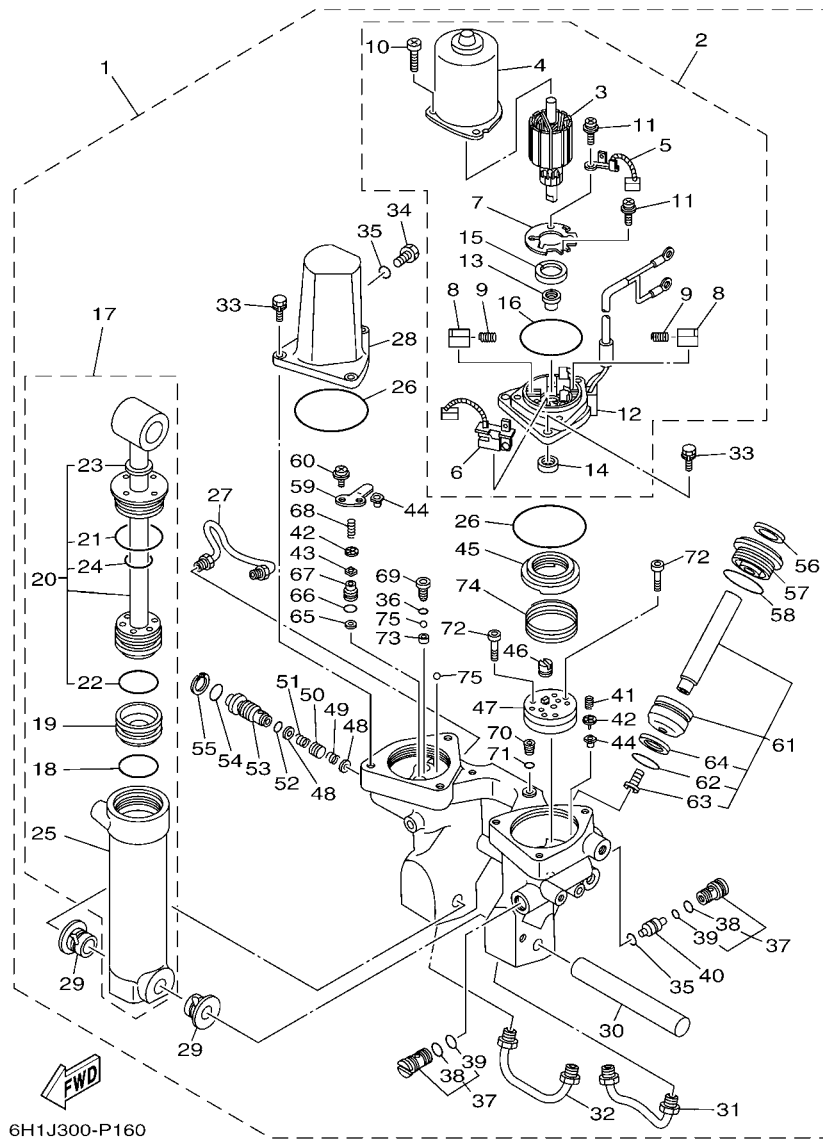

FIG. 16 BRACKET 2

SOPORTE 2

REF. NO.	PART NO. CODIGO Nº	DESCRIPTION DESCRIPCION	ET	EYO	REMARKS OBSERVACIONES
27	90101-10041	BOLT TORNILLO	2	2	
28	90201-20M21	WASHER, PLATE ARANDELA PLANA	2	2	
29	90202-20M06	WASHER, PLATE ARANDELA DE PLANA	2	2	
30	90201-11M22	WASHER, PLATE ARANDELA PLANA	2	2	
31	90185-10027	NUT, SELF-LOCKING TUERCA AUTOBLOCANTE	2	2	
32	663-44575-00	DAMPER, LOWER MOUNT RUBBER AMORTIGUADOR INFERIOR	2	2	
33	688-44511-00	COVER, UPPER MOUNT CUBIERTA AMORTIGUADOR SUPERIOR	1	1	
34	97575-08535	BOLT, WITH WASHER PERNO CON ARANDELA	3	3	
35	6H3-48511-52	HOOK, STEERING GANCHO DIRECCION	1	1	STEERING GUIDE STEERING GUIDE
36	90116-10062	BOLT, STUD ESPARRAGO	2	2	
37	90185-10027	NUT, SELF-LOCKING TUERCA AUTOBLOCANTE	2	2	
38	6H1-43376-00	BOLT, THRUST RECEIVER TORNILLO RECEPTOR	2	2	
39	90185-08057	NUT, SELF-LOCKING TUERCA AUTOBLOCANTE	2	2	
40	90465-11M10	CLAMP BRIDA	3	3	
41	703-82119-00	COVER, LEAD WIRE CUBIERTA DE CABLE CONDUCTOR	1		



6H1J300-P160

FIG. 17 POWER TRIM & TILT ASSY COMPONER Y PODER VARILLA

REF. NO.	PART NO. CODIGO Nº	DESCRIPTION DESCRIPCION	ET	EPO	REMARKS OBSERVACIONES
1	6H1-43800-17-8D	POWER TRIM & TILT ASSY ELEVADOR HIDRAULICO COMPL.	1	1	
2	6H1-43880-02	..MOTOR ASSY ..MOTOR COMPL.	1	1	
3	6H1-43805-10	..ARMATURE ASSY ..INDUCIDO COMPL.	1	1	
4	6H1-43804-10	..STATOR ASSY ..ESTATOR COMPL	1	1	
5	6H1-43891-10	..BRUSH 1 ..ESCOBILLA 1	1	1	
6	6H1-43892-10	..BREAKER COMP. (BRUSH 2) ..RUPTOR COMPLETO (ESCOBILLA 2)	1	1	
7	6H1-4380F-10	..PLATE, BRUSH HOLDER ..PLACA	1	1	
8	6H1-4380J-10	..HOLDER, BRUSH ..PORTAESCOBILLA	2	2	
9	6H1-4386K-10	..SPRING, BRUSH ..RESORTE, ESCOBILLA	2	2	
10	97885-05016	..SCREW, PAN HEAD ..TORNILLO A MUESCA	3	3	
11	97607-04310	..SCREW, WITH WASHER ..TORNILLO CAB CON PLANA C/ARAN	2	2	
12	6H1-43881-10	..FRAME, END ..CUADRO EXTERMO	1	1	
13	6H1-4380H-10	..METAL ..METAL	1	1	
14	93102-08M43	..OIL SEAL ..SELLO ACEITE	1	1	
15	6H1-4380G-10	..PLATE ..PLACA	1	1	
16	6H1-43865-10	..O-RING ..ANILLO EN O 5	1	1	
17	6H1-43840-12	..POWER TILT ASSY ..CONJUNTO COMONER	1	1	
18	6H1-43861-10	..O-RING ..ANILLO EN O 1	1	1	
19	6H1-43814-11	..PISTON, FREE ..PISTON LIBRE	1	1	
20	6H1-43810-12	..TILT PISTON SUB ASSY ..ELEVADOR SUB-PISTON COMPL.	1	1	
21	6H1-43861-00	..O-RING ..ANILLO EN O 1	1	1	
22	6H1-43862-00	..O-RING ..ANILLO EN O 2	1	1	
23	6H1-43812-00	..SEAL, DUST ..SELLO DE POLVO	1	1	
24	6D8-43861-00	..O-RING ..ANILLO EN O 1	1	1	
25	6H1-43813-10	..CYLINDER, TILT ..CILINDRO INCLINACION	1	1	
26	93210-68N50	..O-RING ..ANILLO O	2	2	
27	6H1-43835-10	..PIPE ..TUBO 3	1	1	

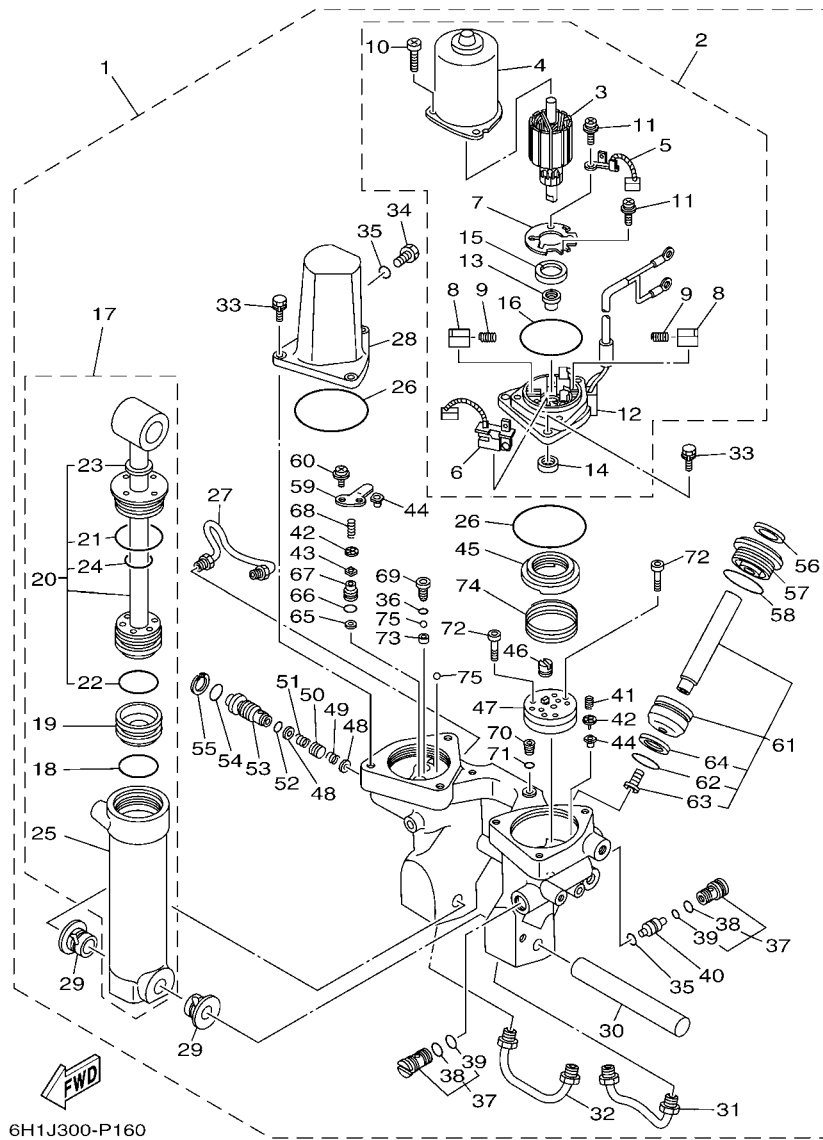

6H1J300-P160

FIG. 17 POWER TRIM & TILT ASSY COMPONER Y PODER VARILLA

REF. NO.	PART NO. CODIGO Nº	DESCRIPTION DESCRIPCION	ET	EPO	REMARKS OBSERVACIONES
28	6H1-43828-10	.BODY, RESERVOIR .CUERPO DEPOSITO	1	1	
29	90386-18M14	.BUSH .BUJE	2	2	
30	6E5-43818-00	.PIN, LOWER SHOCK MOUNT .PASADOR AMORTIGUADOR INFERIOR	1	1	
31	6H1-43833-10	.PIPE .TUBO 1	1	1	
32	6H1-43834-00	.PIPE .TUBO 2	1	1	
33	97595-06420	.BOLT, WITH WASHER .PERNO CON ARANDELA	6	6	
34	6H1-43829-00	.PLUG, RESERVOIR .TAPON DEPOSITO	1	1	
35	93210-09165	.O-RING .ANILLO O	2	2	
36	93210-064A5	.O-RING .ANILLO O	1	1	
37	67F-43802-00	.VALVE SUB ASSY .VALVULA PRINCIPAL COMPL.	2	2	
38	6H1-43866-01	.O-RING .ANILLO EN O 6	1	1	
39	93210-12N52	.O-RING .ANILLO O	1	1	
40	6H1-43841-11	.PISTON, SHUTTLE .PISTON	1	1	
41	6H1-43856-10	.SPRING, DOWN RELIEF .RESORTE SEGURIDAD	1	1	
42	6H1-43844-10	.PIN, VALVE SUPPORT .PASADOR VALVULA SOPORTE	2	2	
43	6H1-4384G-11	.SEAL, RELIEF VALVE .ASIENTO	1	1	
44	6H1-4384F-10	.SEAL, MAIN VALVE .ASIENTO	2	2	
45	6H1-43817-01	.FILTER 2 .FIELTRO 2	1	1	
46	6H1-43831-10	.CONNECTOR, SHAFT .CONEXION EJE	1	1	
47	6H1-43830-11	.GEAR PUMP ASSY .ENGRANAJE BOMBA COMPL.	1	1	
48	6H1-43847-00	.SEAT, MANUAL VALVE .ASIENTO VALVULA MANUAL	2	2	
49	6H1-43899-00	.SPRING, MANUAL RELEASE .PLACA	1	1	
50	6H1-4382A-10	.ADAPTOR 1 .ADAPTADOR 1	1	1	
51	6H1-43854-00	.SPRING, MANUAL RELEASE .RESORTE DESCOPLO MANUAL	1	1	
52	93210-10M74	.O-RING .ANILLO O	1	1	
53	6H1-43845-00	.SCREW, MANUAL RELEASE .TORNILLO DESCOPLO MANUAL	1	1	
54	6D8-43863-00	.O-RING .ANILLO EN O 3	1	1	

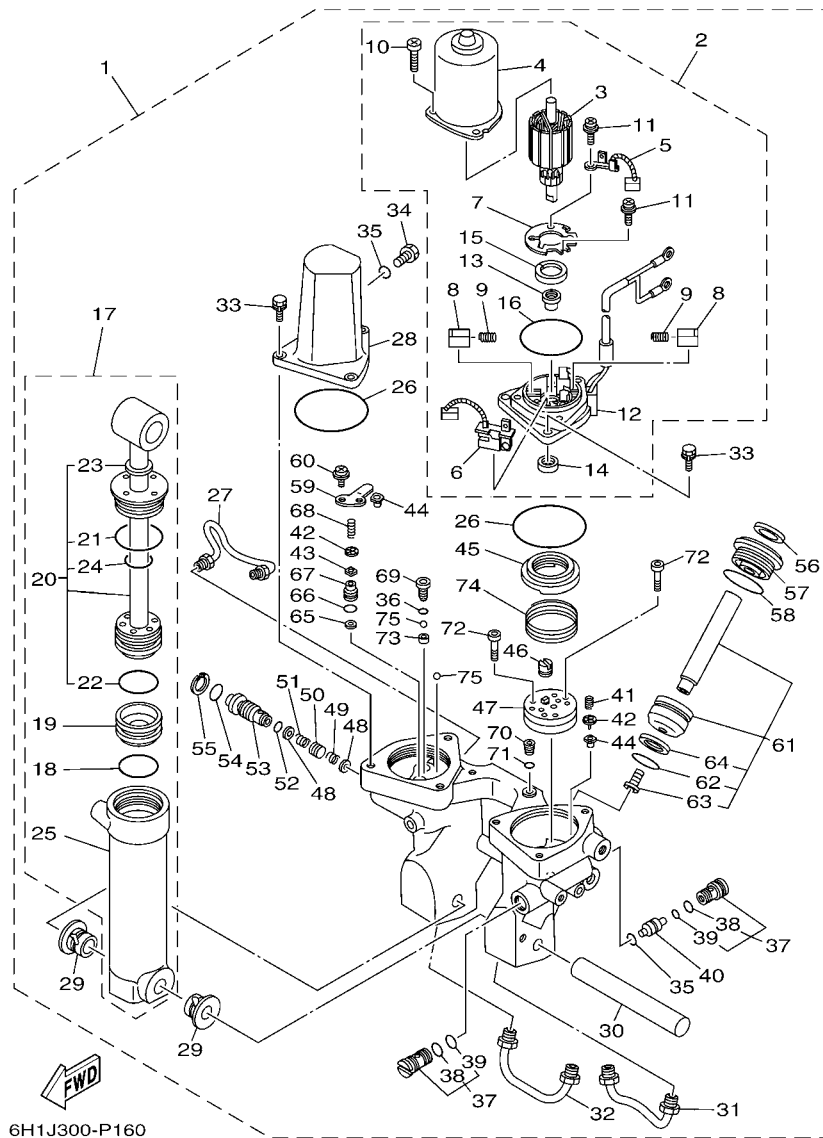

6H1J300-P160

FIG. 17 POWER TRIM & TILT ASSY COMPONER Y PODER VARILLA

REF. NO.	PART NO. CODIGO Nº	DESCRIPTION DESCRIPCION	ET	EPO	REMARKS OBSERVACIONES
55	6H1-43875-00	.RING, SNAP .ANILLO	1	1	
56	6H1-43822-10	.SEAL, TRIM DUST .SELLO DE POLVO	2	2	
57	6H1-43821-11	.SCREW, TRIM CYLINDER END .TORNILLO CILINDURO EXTREMO	2	2	
58	6H1-43861-10	.O-RING .ANILLO EN O 1	2	2	
59	6H1-4384E-20	.SPRING, TRIM .RESORTO	1	1	
60	97602-05210	.SCREW, PAN HEAD WITH WASHER .TORNILLO CON RONDONA	2	2	
61	6H1-43820-11	.TRIM PISTON SUB ASSY .ELEVADOR PISTON COMPL.	2	2	
62	6H1-43864-00	.O-RING .ANILLO EN O 4	1	1	
63	91318-08016	.BOLT, SOCKET HEAD .TORNILLO	1	1	
64	6H1-43874-00	.RING, BACK UP .ANILLO	1	1	
65	6H1-43816-00	.FILTER 1 .FIELTRO 1	1	1	
66	93210-11368	.O-RING .ANILLO O	1	1	
67	6H1-43895-12	.SEAT, RELIEF VALVE .ASIENTO	1	1	
68	6H1-43855-11	.SPRING, UP RELIEF .RESORTE SEGURIDAD SUPERIOR	1	1	
69	6H1-43843-11	.SCREW, VALVE LOCK .TORNILLO	1	1	
70	6H1-4388E-11	.PLUG, TAPER SCREW .TAPON	1	1	
71	6H1-43868-00	.O-RING .ANILLO EN O 8	1	1	
72	91318-04025	.BOLT .TORNILLO	4	4	
73	6H1-4387J-00	.WASHER, SPECIAL 2 .FIELTRO2	1	1	
74	6H1-4385H-00	.SPRING, SEAL .RESORTE	1	1	
75	93505-32038	.BALL .BOLA	2	2	

FIG. 18 UPPER CASING

FUNDA SUPERIOR

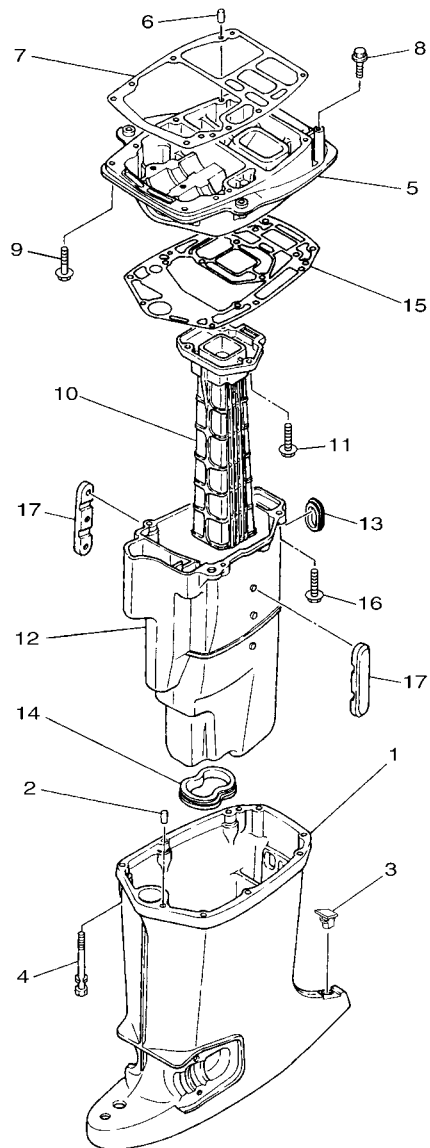

6H3E300-N170

REF. NO.	PART NO. CODIGO Nº	DESCRIPTION DESCRIPCION	ET	EPO	REMARKS OBSERVACIONES
1	6H3-45111-12-4D	CASING, UPPER CAJA SUPERIOR	1	1	L(20.5") L(20.5")
2	93606-12019	PIN, DOWEL PASADOR DE CLAVIJA	2	2	
3	6C5-45155-00	CAP TAPA	1	1	
4	90119-08M81	BOLT, WITH WASHER TORNILLO CON ARANDELA	6	6	
5	6H3-41137-01-CA	GUIDE, EXHAUST GUIA DE ESCAPE	1	1	
6	93606-12019	PIN, DOWEL PASADOR DE CLAVIJA	2	2	
7	6H3-45113-A0	GASKET, UPPER CASING EMPAQUE	1	1	
8	97575-08530	BOLT, WITH WASHER PERNO CON ARANDELA	2	2	
9	97575-08535	BOLT, WITH WASHER PERNO CON ARANDELA	2	2	
10	6H3-41131-00-CA	MANIFOLD, EXT. 1 TUBO MULTIPLE DE ESCAPE		1	70B 70B
	6H2-41131-00-CA	MANIFOLD, EXT. 1 TUBO MULTIPLE DE ESCAPE	1	1	60F 60F
11	97575-08530	BOLT, WITH WASHER PERNO CON ARANDELA	3	3	
12	6H3-14711-11-CA	MUFFLER 1 SILENCIADOR 1	1	1	L(20.5") L(20.5")
13	6H3-45127-00	SEAL SELLO DE GOMA	1	1	
14	6H3-45123-00	GASKET, MUFFLER EMPAQUE SILENCIADOR	1	1	
15	6H3-45114-A1	GASKET, UPPER CASING EMPAQUE	1	1	
16	97575-08530	BOLT, WITH WASHER PERNO CON ARANDELA	4	4	
17	6H3-14737-10	DAMPER, MUFFLER AMORTIGUADOR DE SILENCIADOR	2	2	L(20.5") L(20.5")

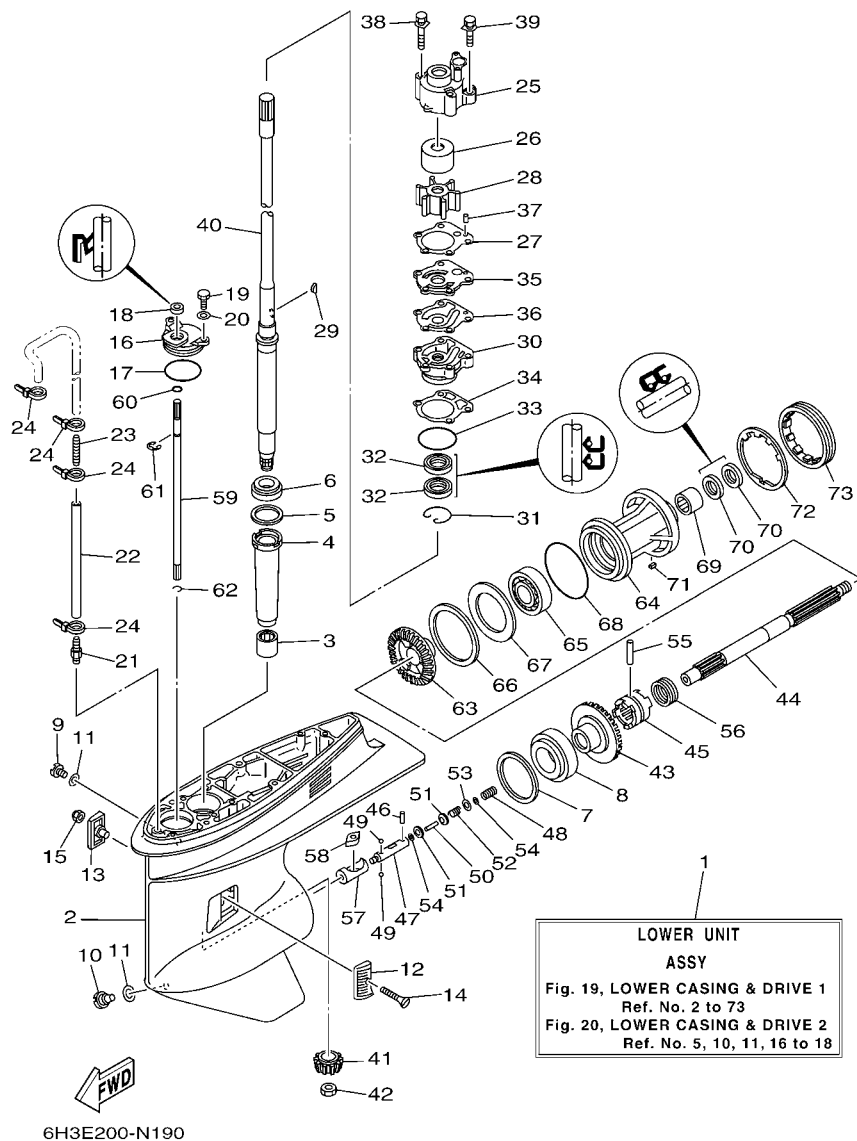

**FIG. 19 LOWER CASING & DRIVE 1 IMPULSOR E INFERIOR 1**

REF. NO.	PART NO. CODIGO Nº	DESCRIPTION DESCRIPCION	LT	EPO	REMARKS OBSERVACIONES
1	6H3-45300-17-4D	LOWER UNIT ASSY CONJUNTO UNIDAD INFERIOR	1	1	L(20.5") L(20.5")
2	6H1-45301-03-4D	CASING, LOWER FUNDA INFERIOR COMPLETA	1	1	
3	93315-325V1	BEARING COJINETE DE RODILLOS	1	1	
4	688-45536-01	SLEEVE, DRIVE SHAFT CAMISA EJE DE MANDO	1	1	
5	688-45587-01	SHIM (T:0.10MM) LAINA (T:0.10MM)	1	1	UR UR
688-45587-10	SHIM (T:0.12MM) LAINA (T:0.12MM)	1	1	UR UR	
688-45587-20	SHIM (T:0.15MM) LAINA (T:0.15MM)	1	1	UR UR	
688-45587-30	SHIM (T:0.18MM) LAINA (T:0.18MM)	1	1	UR UR	
688-45587-40	SHIM (T:0.30MM) LAINA (T:0.30MM)	1	1	UR UR	
688-45587-50	SHIM (T:0.40MM) LAINA (T:0.40MM)	1	1	UR UR	
688-45587-60	SHIM (T:0.50MM) LAINA (T:0.50MM)	1	1	UR UR	
6	93332-000U3	BEARING COJINETE	1	1	
7	688-45567-01	SHIM (T:0.10MM) LAINA (T:0.10MM)	1	1	UR UR
688-45567-10	SHIM (T:0.12MM) LAINA (T:0.12MM)	1	1	UR UR	
688-45567-20	SHIM (T:0.15MM) LAINA (T:0.15MM)	1	1	UR UR	
688-45567-30	SHIM (T:0.18MM) LAINA (T:0.18MM)	1	1	UR UR	
688-45567-40	SHIM (T:0.30MM) LAINA (T:0.30MM)	1	1	UR UR	
688-45567-50	SHIM (T:0.40MM) LAINA (T:0.40MM)	1	1	UR UR	
688-45567-60	SHIM (T:0.50MM) LAINA (T:0.50MM)	1	1	UR UR	
8	93332-000W7	BEARING COJINETE	1	1	
9	90340-08002	PLUG, STRAIGHT SCREW TORNILLO, DE DRENAJE	1	1	
10	688-45341-10	PLUG, DRAIN TAPON, DREN	1	1	
11	90430-08020	GASKET JUNTA	2	2	
12	6H1-45214-00	COVER, WATER INLET 1 CUBIERTA ENTRADA AGUA 1	1	1	
13	6H1-45215-00	COVER, WATER INLET 2 CUBIERTA ENTRADA AGUA 2	1	1	
14	90151-05M00	SCREW, COUNTERSUNK TORNILLO EMBUTIDO	1	1	
15	90185-05002	NUT, NYLON TUERCA AUTOBLOCANTE	1	1	



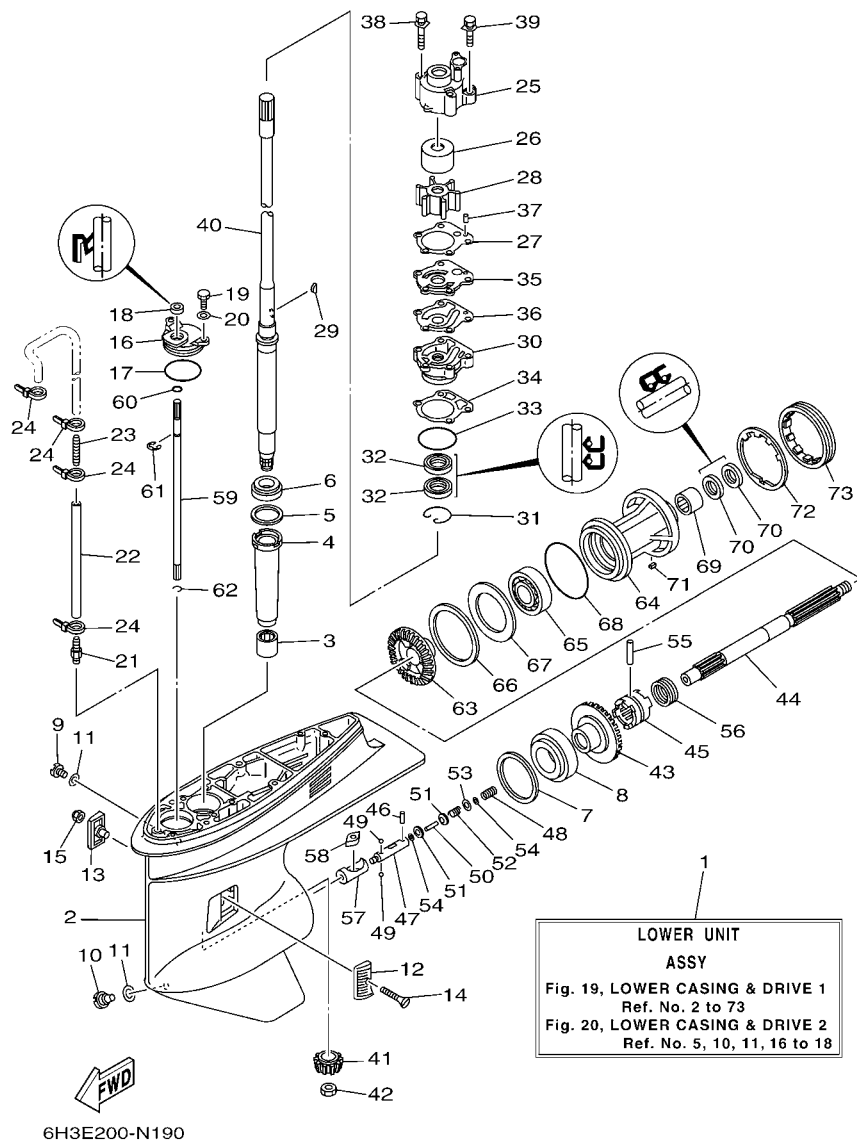

**FIG. 19 LOWER CASING & DRIVE 1      IMPULSOR E INFERIOR 1**

REF. NO.	PART NO. CODIGO Nº	DESCRIPTION DESCRIPCION	ET	EPO	REMARKS OBSERVACIONES
16	688-45321-00	PLATE PLACA	1	1	
17	93210-49046	O-RING ANILLO O	1	1	
18	93106-09014	OIL SEAL SELLO ACEITE	1	1	
19	97095-06016	BOLT PERNO	2	2	
20	92995-06600	WASHER ARANDELA	2	2	
21	6E5-45378-00	NIPPLE, HOSE NIPLE MANGUERA	1	1	
22	90445-07ME9	HOSE (L120) TUBO (L120)	1	1	L(20.5") L(20.5")
23	6E5-83558-10	END, NIPPLE EXTREMO DE NIPLE	1	1	
24	90465-11M10	CLAMP BRIDA	4	4	
25	688-44311-01	HOUSING, WATER PUMP CAJA BOMBA DE AGUA	1	1	L(20.5") L(20.5")
26	688-44322-00	INSERT, CARTRIDGE CARTUCHO	1	1	L(20.5")-STD L(20.5")-STD
	69D-44322-00	INSERT, CARTRIDGE CARTUCHO	1	1	L(20.5")-CHROMATE L(20.5")-CHROMATE
27	688-44315-A0	GASKET, WATER PUMP EMPAQUE	1	1	L(20.5") L(20.5")
28	688-44352-03	IMPELLER IMPULSOR	1	1	L(20.5") L(20.5")
29	90280-04M04	KEY, WOODRUFF CUNA WOODRUFF	1	1	L(20.5") L(20.5")
30	6D8-44341-01-CA	HOUSING, WATER PUMP CAJA BOMBA DE AGUA	1	1	L(20.5") L(20.5")
31	93450-44166	CIRCLIP SEGURO	1	1	L(20.5") L(20.5")
32	93101-25M03	OIL SEAL SELLO ACEITE	2	2	L(20.5") L(20.5")
33	93210-46044	O-RING ANILLO O	1	1	
34	688-44316-A0	GASKET, WATER PUMP EMPAQUE	1	1	
35	688-44323-00	OUTER PLATE, CARTRIDGE PLACA EXTERIOR DEL CARTUCHO	1	1	L(20.5")-STD L(20.5")-STD
	688-44323-40	OUTER PLATE, CARTRIDGE PLACA EXTERIOR DEL CARTUCHO	1	1	L(20.5")-CHROMATE L(20.5")-CHROMATE
36	688-44324-A0	GASKET, CARTRIDGE EMPAQUE	1	1	L(20.5") L(20.5")
37	93604-10M03	PIN, DOWEL PASADOR DE CLAVIJA	2	2	
38	90119-08M16	BOLT, WITH WASHER TORNILLO CON ARANDELA	2	2	L(20.5") L(20.5")
39	90119-08M13	BOLT, WITH WASHER TORNILLO CON ARANDELA	2	2	L(20.5") L(20.5")
40	6H3-45501-11	DRIVE SHAFT COMP. EJE DE MANDO COMPL.	1	1	L(20.5") L(20.5")

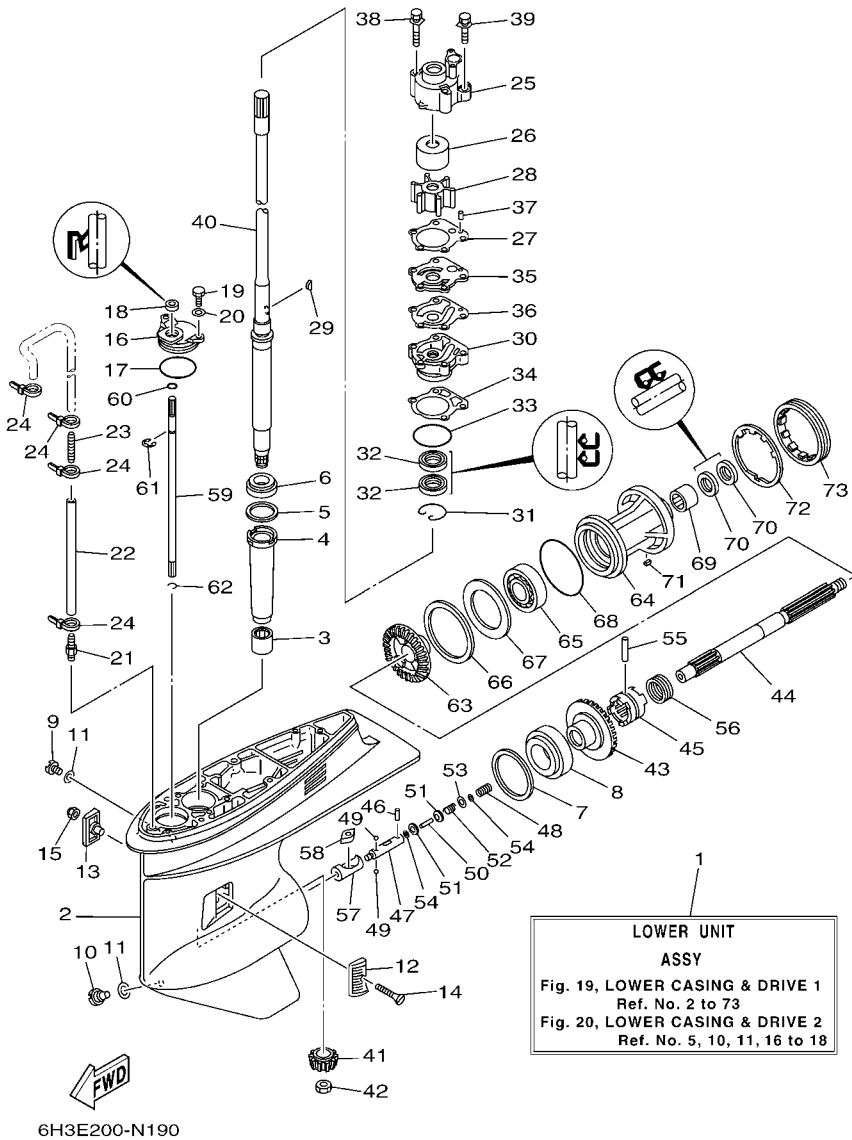
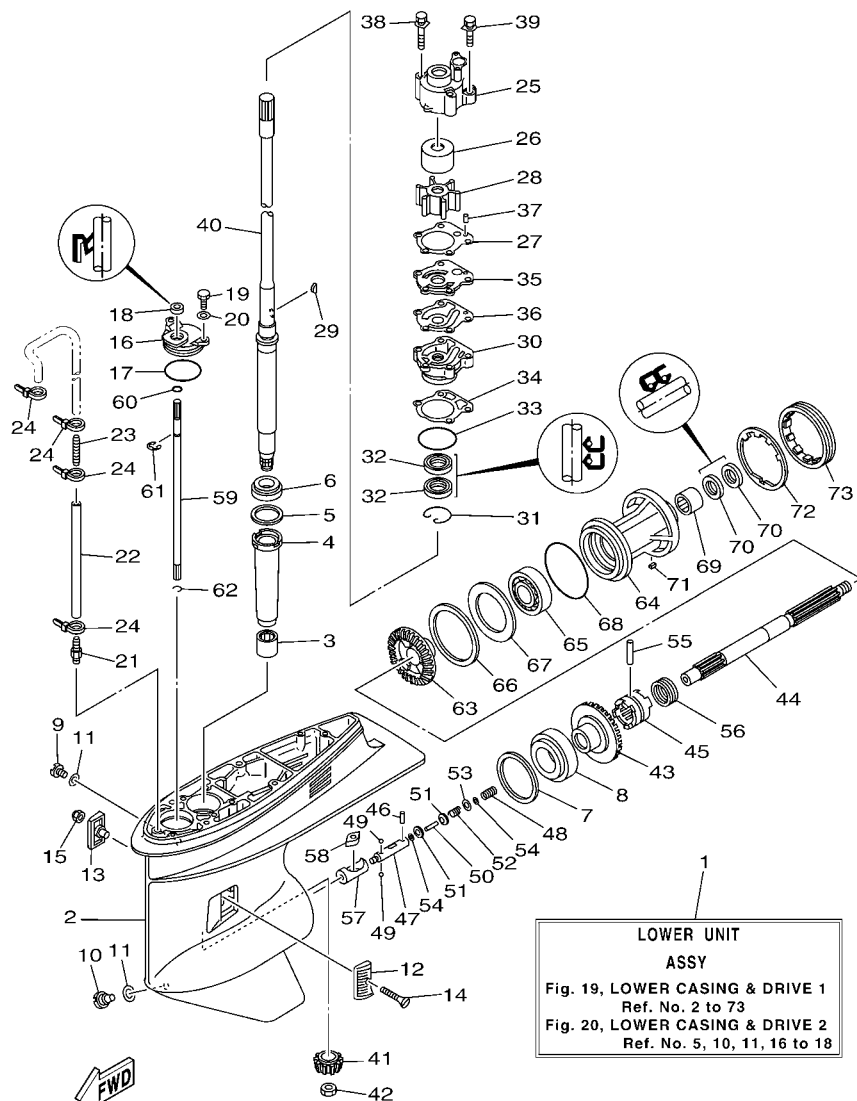

**FIG. 19 LOWER CASING & DRIVE 1 IMPULSOR E INFERIOR 1**

REF. NO.	PART NO. CODIGO Nº	DESCRIPTION DESCRIPCION	ET	E/O	REMARKS OBSERVACIONES
41	6K5-45551-00	PINION (12T) PINON (12T)	1	1	
42	90170-16M01	NUT TUERCA	1	1	
43	6K5-45560-00	GEAR 1 (28T) ENGRANAJE 1 (28T)	1	1	
44	6H1-45611-01	SHAFT, PROPELLER EJE PROPUSOR	1	1	
45	6H1-45631-01	CLUTCH, DOG EMBRAGUE DE GARRA	1	1	
46	93603-12M11	PIN, DOWEL PASADOR DE CLAVIJA	1	1	
47	6H1-45634-02	SLIDE, SHIFT DESIZADOR, CAMBIO	1	1	
48	90501-16M65	SPRING, COMPRESSION RESORTE DE COMPRESION	1	1	
49	93503-16003	BALL ESFERA	2	2	
50	6H1-45668-00	SHAFT, FREE 1 EJE 1	1	1	
51	6H1-45635-00	PLUNGER, SHIFT EMBOLO DE CAMBIO	2	2	
52	90501-12M48	SPRING, COMPRESSION RESORTE DE COMPRESION	1	1	
53	90201-03313	WASHER, PLATE ARANDELA PLANA	1	1	
54	90183-02M03	NUT, SPRING TUERCA DE RESORTE	2	2	
55	90250-07M02	PIN, STRAIGHT PASADOR CILINDRICO	1	1	
56	688-45633-00	RING, CROSS PIN ANILLO DE PASADOR	1	1	
57	6H1-45641-01	SHIFTER CAMBIO	1	1	
58	6H1-44151-00	CAM, SHIFT LEVA DE CAMBIO	1	1	
59	6H1-44144-00	ROD, SHIFT VARILLA DE CAMBIO	1	1	
60	93210-07003	O-RING ANILLO O	1	1	
61	99001-08600	CIRCLIP PRESILLA REDONDA	1	1	
62	93450-07M00	CIRCLIP SEGURO	1	1	
63	6H3-45571-00	GEAR (28T) ENGRANAJE (28T)	1	1	
64	688-45331-00-CA	HOUSING, BEARING CAJA DE COJINETE	1	1	
65	93306-207U0	BEARING COJINETE	1	1	
66	688-45577-01	SHIM (T:0.10MM) LAINA (T:0.10MM)	1	1	UR UR
	688-45577-10	SHIM (T:0.12MM) LAINA (:0.12MM)	1	1	UR UR

FIG. 19 LOWER CASING & DRIVE 1

IMPULSOR E INFERIOR 1



6H3E200-N190

REF. NO.	PART NO. CODIGO Nº	DESCRIPTION DESCRIPCION	ET	EIO	REMARKS OBSERVACIONES
66	688-45577-20	SHIM (T:0.15MM) LAINA (T:0.15MM)	1	1	UR
	688-45577-30	SHIM (T:0.18MM) LAINA (T:0.18MM)	1	1	UR
	688-45577-40	SHIM (T:0.30MM) LAINA (T:0.30MM)	1	1	UR
	688-45577-50	SHIM (T:0.40MM) LAINA (T:0.40MM)	1	1	UR
	688-45577-60	SHIM (T:0.50MM) LAINA (T:0.50MM)	1	1	UR
67	688-45576-00	WASHER, THRUST 2 ARANDELA DE EMPUJE AXIAL 2	1	1	
68	93210-85M97	O-RING ANILLO O	1	1	
69	93317-325U0	BEARING COJINETE	1	1	
70	93101-25M03	OIL SEAL SELLO ACEITE	2	2	
71	90282-04010	KEY, STRAIGHT CHAVETA, RECTA	1	1	
72	688-45383-02	WASHER, CLAW ARANDELA DE UNA	1	1	
73	688-45384-02	NUT TUERCA	1	1	

FIG. 20 LOWER CASING & DRIVE 2 IMPULSOR E INFERIOR 2

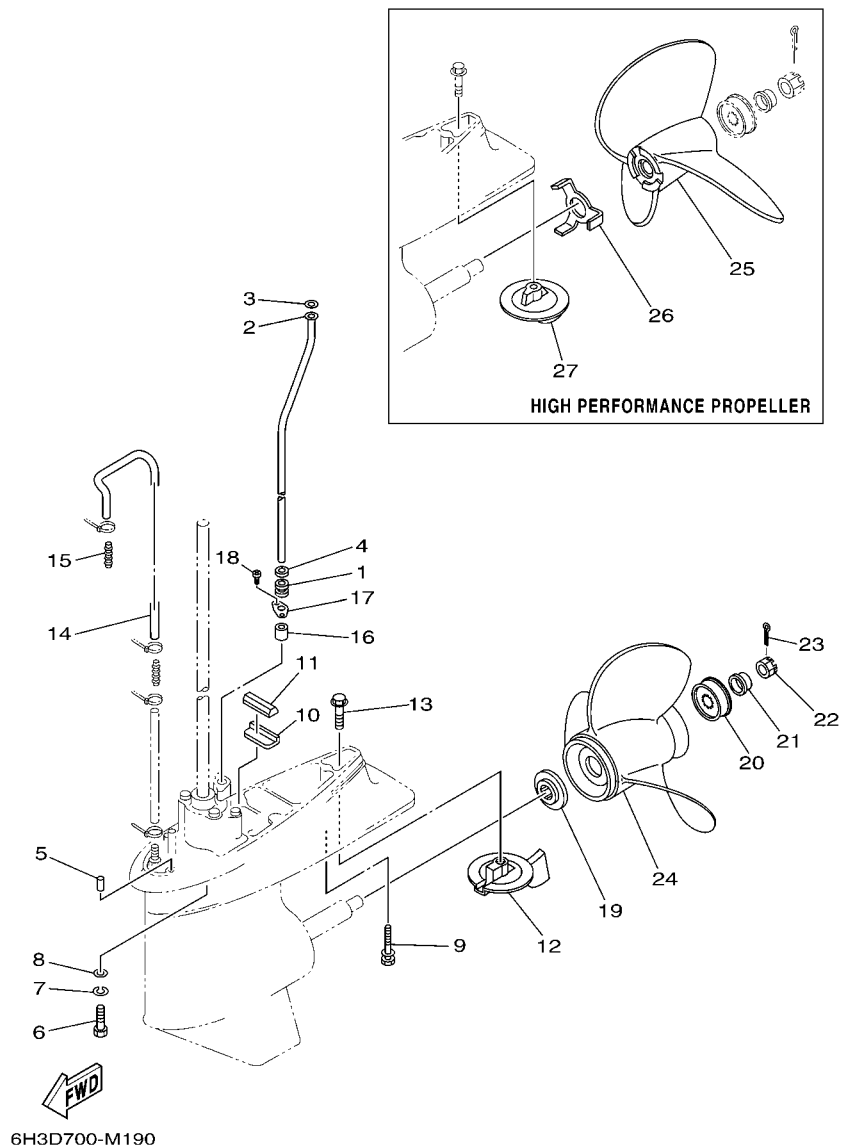

REF. NO.	PART NO. CODIGO Nº	DESCRIPTION DESCRIPCION	ET	EPO	REMARKS OBSERVACIONES
1	663-44367-00	DAMPER, WATER SEAL 3 GOMA DEL SELLO DE AGUA 3	1	1	
2	6H3-44361-11	TUBE, WATER 1 TUBO DE AGUA 1	1	1	L(20.5") L(20.5")
3	90202-12060	WASHER, PLATE ARANDELA DE PLANA	1	1	
4	90430-12072	GASKET JUNTA	1	1	
5	93606-12019	PIN, DOWEL PASADOR DE CLAVIJA	2	2	
6	97075-10040	BOLT PERNO	4	4	
7	92990-10100	WASHER, SPRING ARANDELA PLANA	4	4	
8	92990-10600	WASHER, PLATE ARANDELA PLANA	4	4	
9	97575-08560	BOLT, WITH WASHER PERNO CON ARANDELA	1	1	
10	663-45376-00	GUIDE, SEAL DAMPER GUIA DE SELLO GOMA	1	1	
11	688-45375-00	DAMPER, SEAL GOMA DE SELLO	1	1	
12	67F-45371-00	TAB-TRIM QUILLA ESTABILIZADOR	1	1	
13	90105-10M67	BOLT, FLANGE TORNILLO	1	1	
14	90445-07MF1	HOSE (L570) TUBO (L570)	1	1	
15	6E5-83558-00	END, NIPPLE EXTREMO DE NIPLE	1	1	
16	663-44366-00	DAMPER, WATER SEAL 2 GOMA DEL SELLO DE AGUA 2	1	1	
17	90480-19M06	GROMMET TAPON	1	1	L(20.5") L(20.5")
18	90160-04006	SCREW, ROUND TAPPING TORNILLO REDONDO ROSCA HEMBRA	2	2	L(20.5") L(20.5")
19	688-45987-01	SPACER 1 ESPACIADOR 1	1	1	
20	67F-45997-00	SPACER 2 ESPACIADOR 2	1	1	
21	90389-25M00	BUSH BUJE	1	1	
22	90171-16011	NUT, CASTLE TUERCA ENTALLADA	1	1	
23	91490-30025	PIN, COTTER CHAVETA	1	1	
24	6E5-45941-00	PROPELLER (3X13"X19"-K) PROPELA (3X13"X19"-K)	1	1	UR UR
	6E5-45943-00	PROPELLER (3X12-5/8"X21"-K) PROPELA (3X12-5/8"X21"-K)	1	1	UR UR
	6E5-45945-01	PROPELLER (3X13-1/4"X17"-K) PROPELA (3X13-1/4"X17"-K)	1	1	UR UR
	6E5-45947-00	PROPELLER (3X13-1/2"X15"-K) PROPELA (3X13-1/2"X15"-K)	1	1	UR UR

FIG. 20 LOWER CASING & DRIVE 2 IMPULSOR E INFERIOR 2

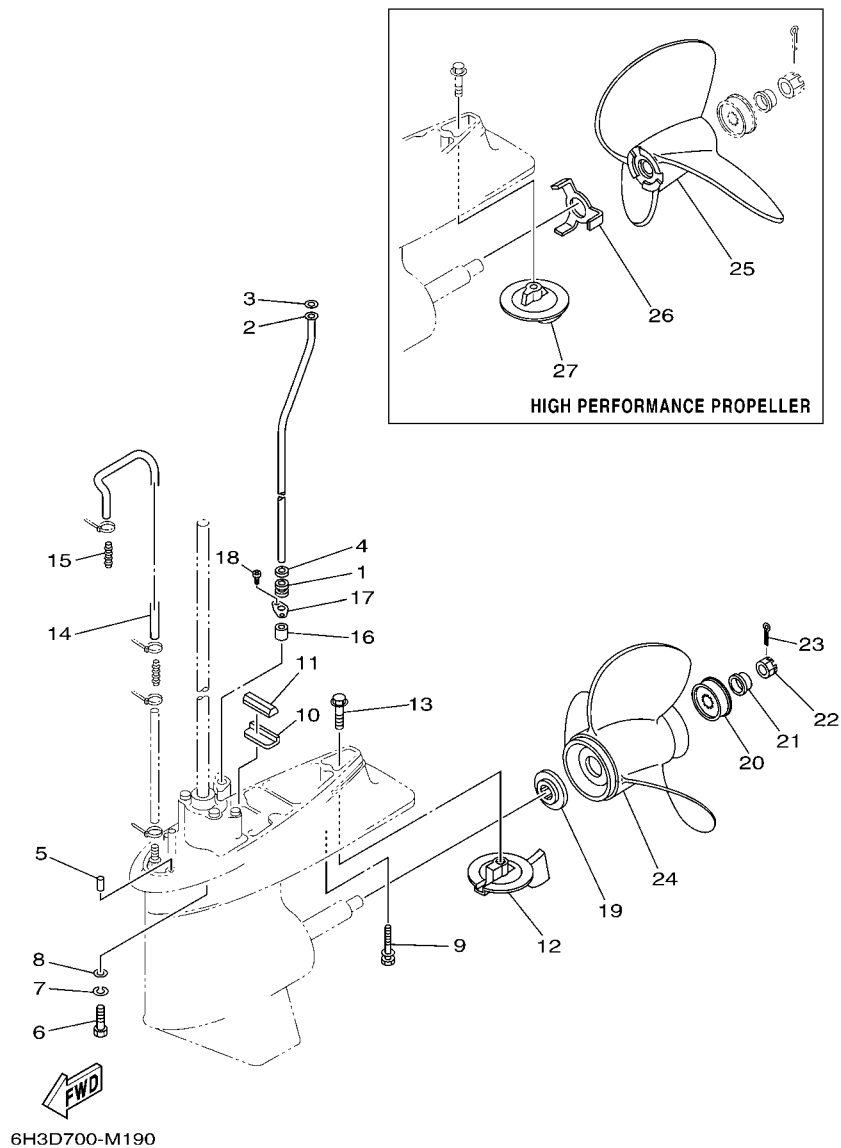

REF. NO.	PART NO. CODIGO Nº	DESCRIPTION DESCRIPCION	ET	EPO		REMARKS OBSERVACIONES
24	6E5-45949-00	PROPELLER (3X13-5/8"X13"-K) PROPELA (3X13-5/8"X13"-K)	1	1		UR
	6E5-45952-00	PROPELLER (3X13"X23"-K) PROPELA (3X13"X23"-K)	1	1		UR
	6E5-45954-00	PROPELLER (3X14"X11"-K) PROPELA (3X14"X11"-K)	1	1		UR
	6E5-45956-00	PROPELLER (3X13"X25"-K) PROPELA (3X13"X25"-K)	1	1		UR
	688-45930-02	PROPELLER (3X13"X17"-K2) PROPELA (3X13"X17"-K2)	1	1		UR
	688-45970-03	PROPELLER (3X13"X19"-K) PROPELA (3X13"X19"-K)	1	1		UR
	688-45972-02	PROPELLER (3X13"X21"-K) PROPELA (3X13"X21"-K)	1	1		UR
	688-45974-02	PROPELLER (3X13"X23"-K) PROPELA (3X13"X23"-K)	1	1		UR
	688-45976-01	PROPELLER (3X13"X25"-K) PROPELA (3X13"X25"-K)	1	1		UR
	688-45932-60	PROPELLER (3X13-1/2"X14"-K) PROPELA (3X13-1/2"X14"-K)	1	1		UR
	688-45978-60	PROPELLER (3X13-1/2"X16"-K) PROPELA (3X13-1/2"X16"-K)	1	1		UR
25	6E5-45970-10	PROPELLER (3X14"X20"-P) PROPELA (3X14"X20"-P)	1	1		UR
	6E5-45972-10	PROPELLER (3X14"X24"-P) PROPELA (3X14"X24"-P)	1	1		UR
	6E5-45974-10	PROPELLER (3X14"X28"-P) PROPELA (3X14"X28"-P)	1	1		UR
	6E5-45976-10	PROPELLER (3X14"X22"-P) PROPELA (3X14"X22"-P)	1	1		UR
	6E5-45978-10	PROPELLER (3X14"X26"-P) PROPELA (3X14"X26"-P)	1	1		UR
26	6E5-45994-10	PLATE, TOOTH PLACA	1	1		
27	6E5-45371-10	TAB-TRIM QUILLA ESTABILIZADOR	1	1		

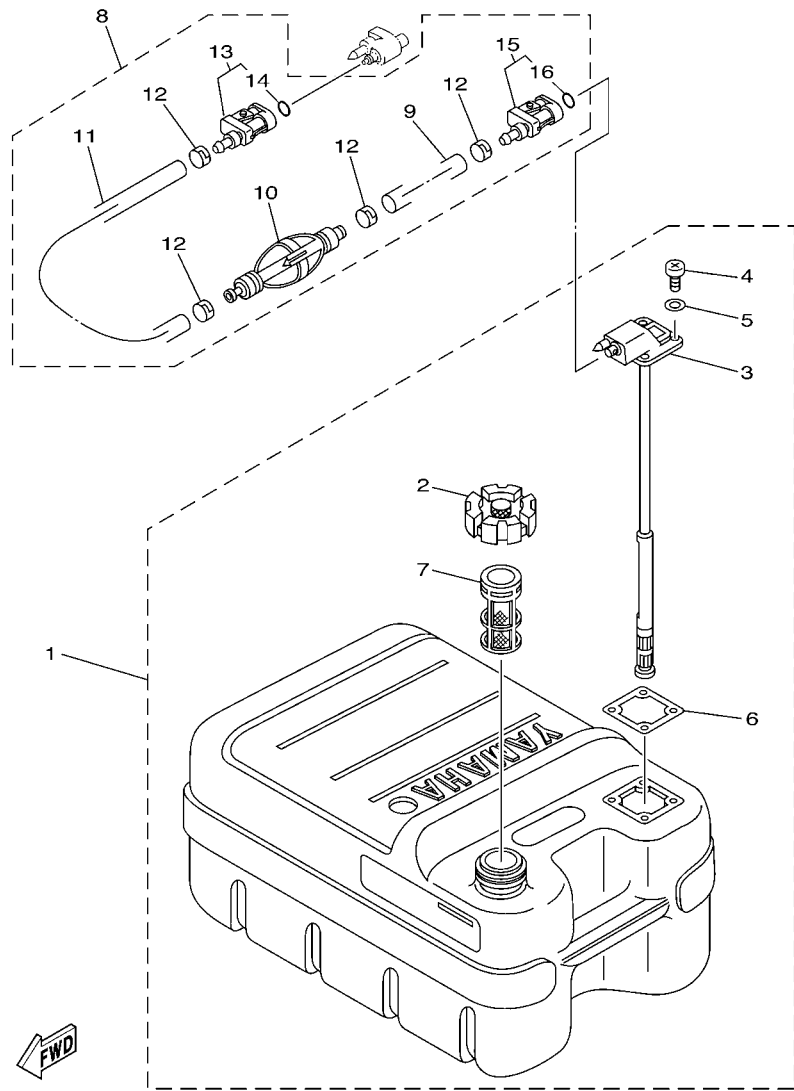
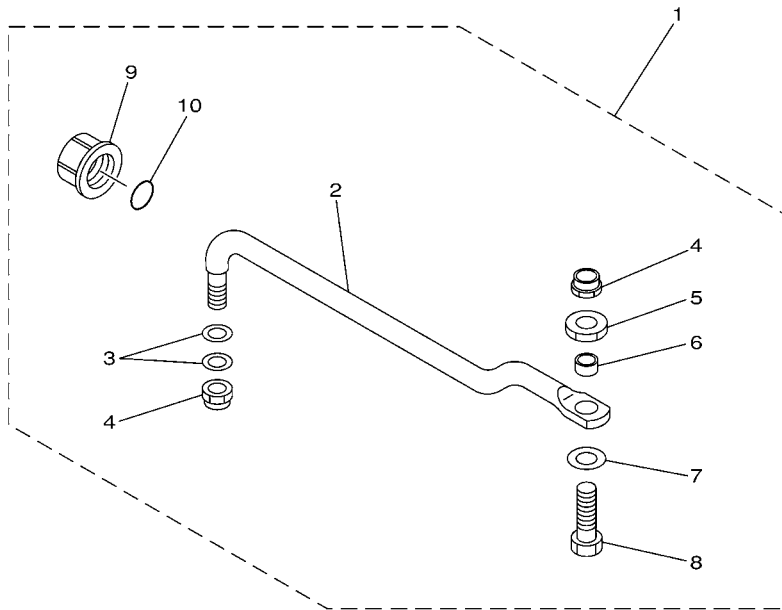

FIG. 21 FUEL TANK

DEPOSITO DE COMBUSTIBLE

REF. NO.	PART NO. CODIGO Nº	DESCRIPTION DESCRIPCION	LT	ETO		REMARKS OBSERVACIONES
1	6YJ-24201-00	FUEL TANK ASSY (24L) TANQUE DEL COMBUSTIBLE (24L)	1	1		AP EXCEPT FOR BRA AP EXCEPT FOR BRA
2	6YJ-24610-01	.CAP ASSY .TAPA COMPLETA	1	1		
3	6YJ-24260-00	.FUEL METER ASSY .MEDIDOR DE COMBUSTIBLE COMPL.	1	1		
4	90157-05M19	.SCREW, PAN HEAD .TORNILLO CABEZA CONICA PLANA	4	4		
5	6Y1-24329-00	.SEAL .SELLO	4	4		
6	6Y1-24268-00	.GASKET, FUEL METER .EMPAQ MEDIDOR DE COMBUSTIBLE	1	1		
7	6YJ-24167-00	.STRAINER .COLADOR	1	1		
8	61J-24306-04	FUEL PIPE COMP. 1 TUBO COMBUST. COMPL 1	1	1		AP AP
9	90445-11M06	.HOSE (L2050) .MANGUERA (L2050)	1	1		
10	61J-24360-00	.PRIMER PUMP ASSY .SOPORTE BOMBA	1	1		
11	90445-11M05	.HOSE (L850) .MANGUERA (L850)	1	1		
12	650-24351-51	.BAND 1 .ABRAZADERA 1	4	4		
13	6G1-24305-05	.FUEL PIPE JOINT COMP. 2 .CONECTOR MANGUERA COMBUST. 2	1	1		
14	93210-08287	..O-RING ..ANILLO O	1	1		
15	6Y1-24305-06	.FUEL PIPE JOINT COMP. 2 .CONECTOR MANGUERA COMBUST. 2	1	1		
16	93210-08287	..O-RING ..ANILLO O	1	1		



6880700-9190

FIG. 22 STEERING GUIDE

DIRECCIONGUIAR

REF. NO.	PART NO. CODIGO Nº	DESCRIPTION DESCRIPCION	LT	ETP		REMARKS OBSERVACIONES
1	688-61350-10	STEERING GUIDE ATTACHMENT KIT ESTUCHE ADITAMENTO GUIA DE TIM	1	1		AP EXCEPT FOR AFR AP EXCEPT FOR AFR
2	688-61351-10	.ROD, STEERING LINK .VARILLA ESLABON DIRECCION	1	1		
3	90201-10M20	.WASHER, PLATE .ARANDELA PLANA	2	2		
4	90185-09M01	.NUT, SELF-LOCKING .TUERCA AUTOBLOCANTE	2	2		
5	90170-09M03	.NUT .TUERCA	1	1		
6	90387-10M42	.COLLAR .ESPACIADOR	1	1		
7	90201-10M63	.WASHER, PLATE .ARANDELA PLANA	1	1		
8	6E5-61355-00	.BOLT .TORNILLO	1	1		
9	6E5-43145-01	.CAP, CLAMP BRACKET .TAPA	1	1		
10	93210-16275	.O-RING .ANILLO O	1	1		

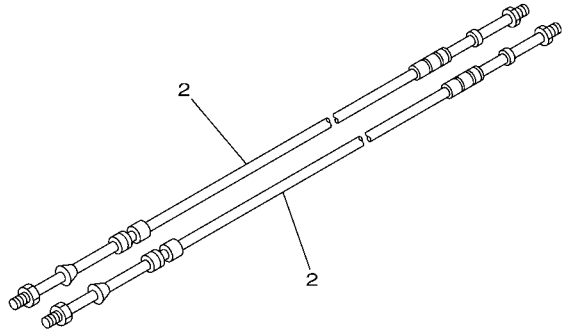
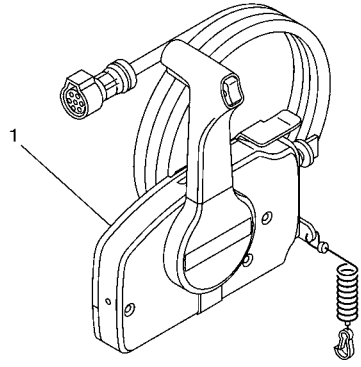

63PD370-P320

FIG. 23 REMOTE CONTROL BOX

CONTROL REMOTO COMPLETO

REF. NO.	PART NO. CODIGO Nº	DESCRIPTION DESCRIPCION	ET	EPO		REMARKS OBSERVACIONES
1	703-48205-B0	REMOTE CONTROL ASSY (10P, PTT) REMOTO CONTROL COMPL. (10P)	1	1		AP WITH PT/T SW. AP WITH PT/T SW.
	703-48207-20	REMOTE CONTROL ASSY (10P, PTT) REMOTO CONTROL COMPL. (10P)		1		AP FOR BRA,ARG AP FOR BRA,ARG
2	701-48320-20	CABLE, REMOTE CONTROL L=13F CABLE CONTROL REMOTO L=13F	2	2		UR UR
	701-48320-30	CABLE, REMOTE CONTROL L=14F CABLE CONTROL REMOTO L=14F	2	2		UR UR
	701-48320-40	CABLE, REMOTE CONTROL L=19F CABLE CONTROL REMOTO L=19F	2	2		UR UR
-----						
-----						
-----						
-----						
-----						
-----						
-----						
-----						
-----						
-----						



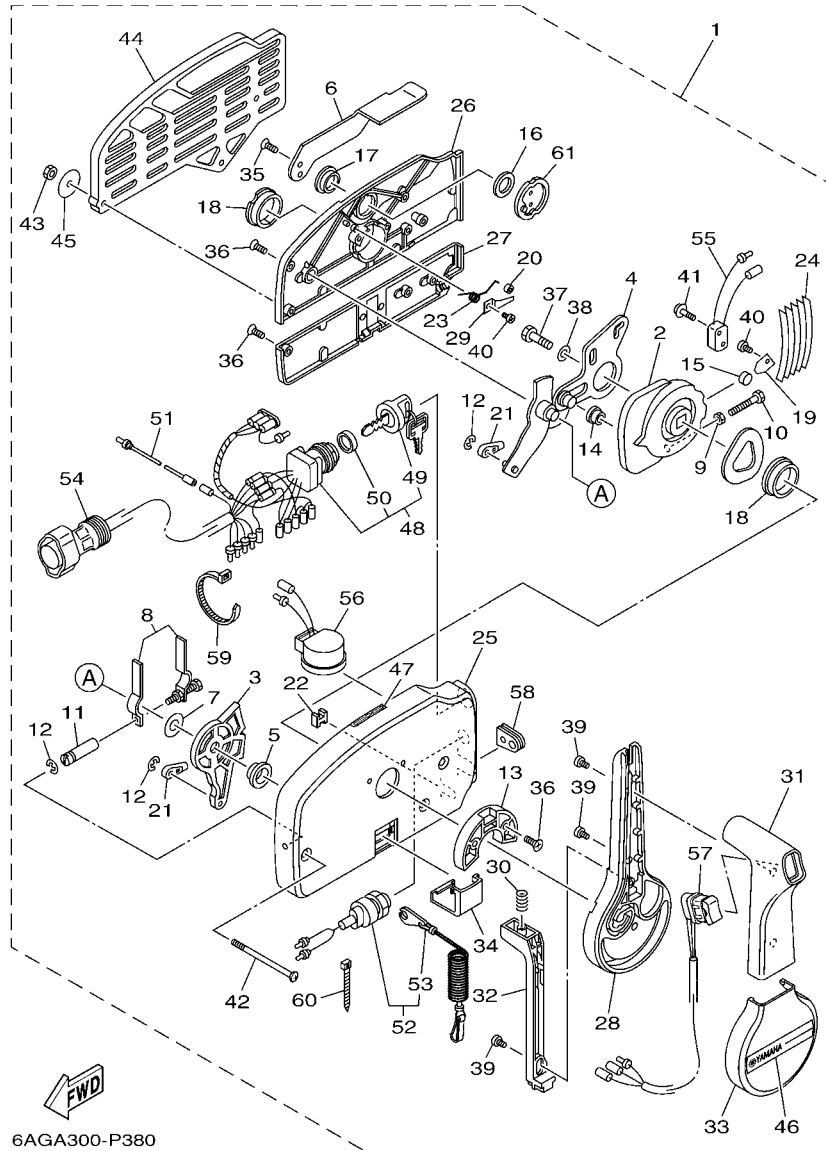

6AGA300-P380

FIG. 24 REMOTE CONTROL ASSY 1 CONTROL REMOTO COMPL 1

REF. NO.	PART NO. CODIGO Nº	DESCRIPTION DESCRIPCION	LT	EPO		REMARKS OBSERVACIONES
1	703-48205-B0	REMOTE CONTROL ASSY (10P, PTT) REMOTO CONTROL COMPL. (10P)	1	1		AP WITH PT/T SW. AP WITH PT/T SW.
2	703-48232-00	.GEAR .ENGRANAJE 1	1	1		
3	703-48271-00	.ARM, SHIFT .BRAZO CAMBIADOR	1	1		
4	703-48261-01	.ARM, THROTTLE .BRAZO ACELERADOR	1	1		
5	703-48235-00	.BUSHING .BUJE	1	1		
6	703-48152-10	.KNOB, FREE ACCEL. .PERILLA	1	1		
7	703-48268-00	.SPACER .ESPACIADOR 3	1	1		
8	703-48264-00	.FRICTION, THROTTLE .FRICCION DE ACELERADOR	1	1		
9	95380-05600	.NUT .TUERCA	1	1		
10	97380-05025	.BOLT .TORNILLO HEXAGONAL	1	1		
11	703-48265-00	.SHAFT, FRICTION .EJE FRICCION	1	1		
12	93430-06024	.CIRCLIP .SEGURO	3	3		
13	703-48245-00	.PLATE, LOCK .PLACA CERRADURA	1	1		
14	703-48252-00	.ROLLER, CAM .RODILLO LEVA	1	1		
15	701-48248-00	.ROLLER, FREE ACCEL. .RODILLO ACELERADOR LIBRE	1	1		
16	703-48198-00	.WASHER, WAVE .RONDANA ONDULADA 3	1	1		
17	703-48243-00	.BUSHING .BUJE 3	1	1		
18	703-48236-00	.BUSHING 1 .BUJE	2	2		
19	703-48189-00	.RETAINER .RETENEDOR	1	1		
20	703-48234-00	.ROLLER, DETENT .RODILLO	1	1		
21	703-48345-01	.CABLE END, REMOTE CONTROL 2 .TERMINAL CABLE DE CONTROL REMO	2	2		
22	703-48358-00	.ANCHOR, CABLE .ABRAZADERA CABLE	1	1		
23	703-48244-00	.SPRING, FREE ACCEL. .RESORTE ACELERADOR LIBRE	1	1		
24	703-48238-00	.SPRING, DETENT .RESORTE	5	5		
25	703-48211-10	.HOUSING,1 .CAJA	1	1		
26	703-48212-10	.BACK PLATE 1 .PLACA TRASERA 1	1	1		
27	703-48213-10	.BACK PLATE 2 .PLACA TRASERA 2	1	1		

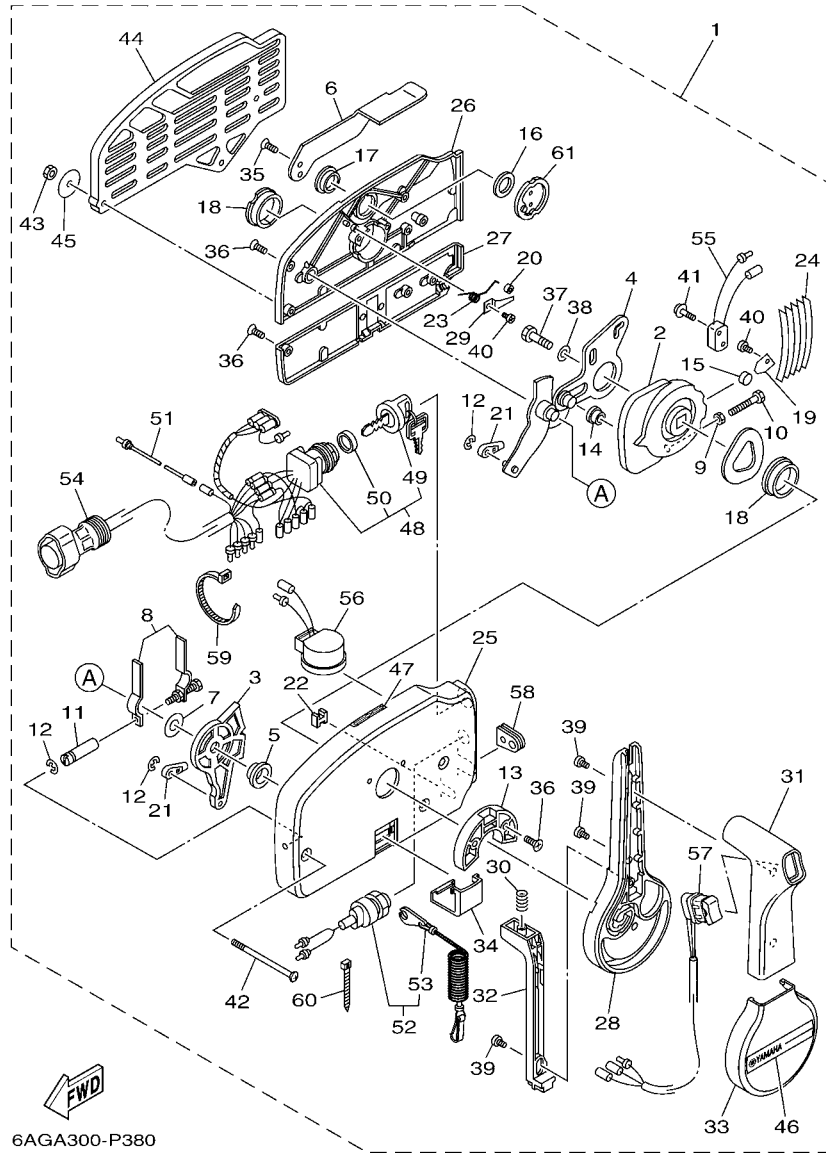

FIG. 24 REMOTE CONTROL ASSY 1 CONTROL REMOTO COMPL 1

REF. NO.	PART NO. CODIGO Nº	DESCRIPTION DESCRIPCION	ET	E/O		REMARKS OBSERVACIONES
28	703-48221-10	.LEVER, CONTROL .PALANCA CONTROL	1	1		
29	703-48246-00	.SPACER .ESPACIADOR	1	1		
30	703-48227-00	.SPRING, NEUTRAL LOCK .RESORTE DE SEGURO	1	1		
31	703-48222-20	.GRIP, CONTROL LEVER .MANGO DE PALANCA CONTROL	1	1		SINGLE SINGLE
32	703-48223-10	.LOCK, NEUTRAL .CERRADURA NEUTRO	1	1		
33	703-48225-10	.COVER .CUBIERTA	1	1		
34	703-48219-10	.COVER, LEAD .CUBIERTA	1	1		
35	703-48281-00	.SCREW .TORNILLO 1	2	2		
36	703-44189-20	.SCREW .TORNILLO	7	7		
37	97380-08030	.BOLT .TORNILLO HEXAGONAL	1	1		
38	92990-08600	.WASHER, PLATE .ARANDELA PLANA	1	1		
39	703-48128-10	.SCREW 2 .TORNILLO 2	3	3		
40	98580-04006	.SCREW, PAN HEAD .TORNILLO DE CABEZA CRUZADA	2	2		
41	703-48129-00	.SCREW 3 .TORNILLO 3	2	2		
42	703-44189-30	.SCREW .TORNILLO	3	3		
43	95380-06600	.NUT, HEXAGON .TUERCA	3	3		
44	703-48293-10	.SPACER, REMOTE CONTROL .ESPACIADOR	1	1		SINGLE SINGLE
45	701-48287-00	.WASHER .ARANDELA	3	3		
46	703-48215-10	.GRAPHIC .CALCOMANIA 1	1	1		
47	6X3-44191-00	.INDICATOR, SHIFT .INDICADOR DE CAMBIOS	1	1		
48	703-82510-13	.MAIN SWITCH ASSY .CONJUNTO DE LLAVE IGNICION	1	1		PRIME START PRIME START
49	676-82577-01	.CAP, KEY .TAPA	1	1		
50	703-82532-00	.CAP .TAPA	1	1		
51	703-82531-00	.WIRE, LEAD (L70) .CABLE CONDUCTOR (L70)	1	1		
52	688-82575-01	.ENGINE STOP SWITCH ASSY .INTERRUPTOR DE PARADA COMPL	1	1		
53	682-82556-00	.LANYARD, STOP SWITCH .CORDON DE INTERRUPTOR PARADA	1	1		
54	688-8258A-20	.EXTENSION, WIRE HARNESS (4.9M) .EXTENSION, ARNES DE CABLES (4.	1	1		(10P) (10P)

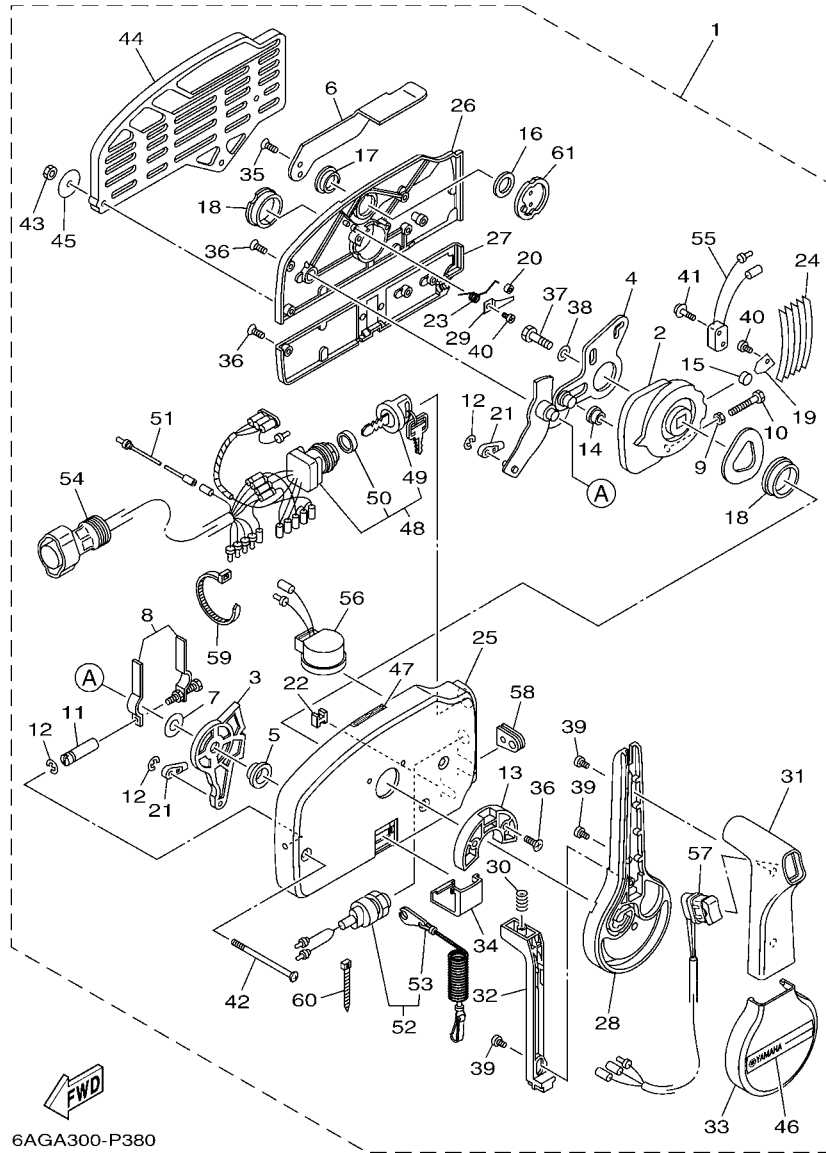
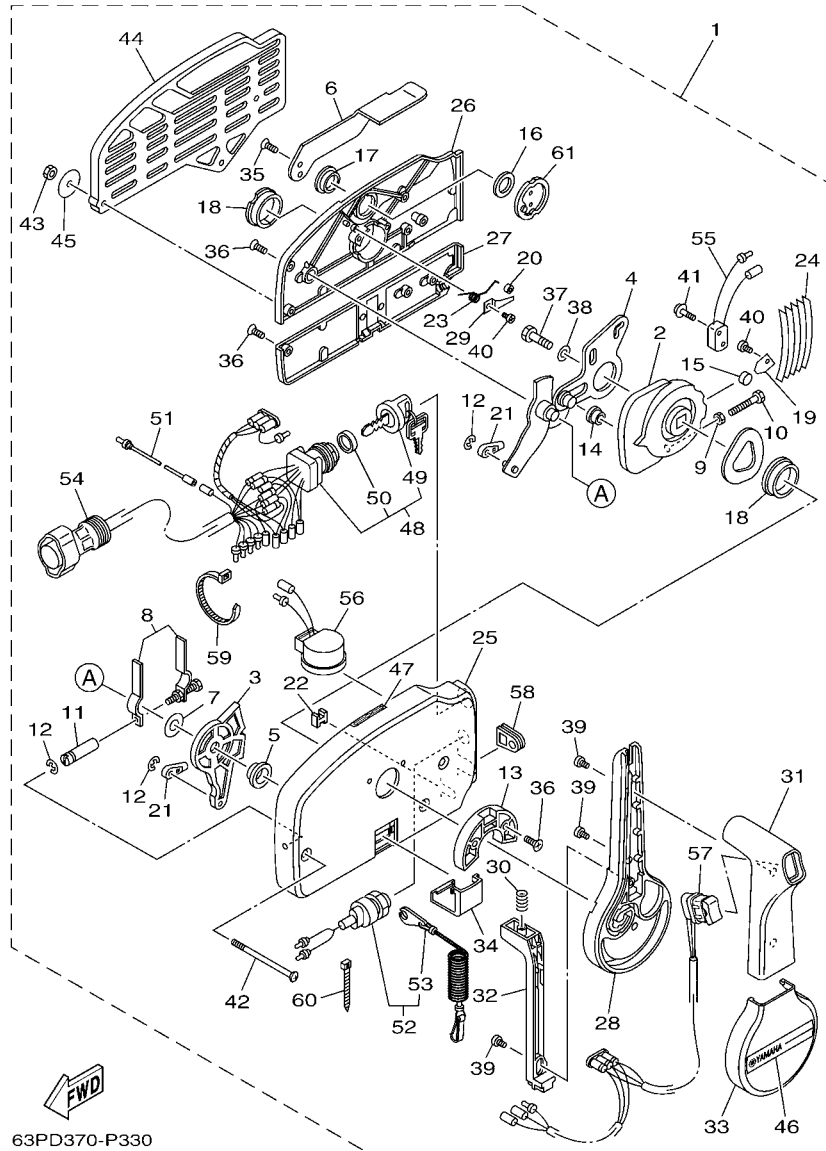

FIG. 24 REMOTE CONTROL ASSY 1 CONTROL REMOTO COMPL 1

REF. NO.	PART NO. CODIGO Nº	DESCRIPTION DESCRIPCION	ET	ETO	REMARKS OBSERVACIONES
55	703-82540-00	.NEUTRAL SWITCH ASSY .INTERRUPTOR NEUTRAL COMPL	1	1	
56	703-83383-11	.BUZZER .ZUMBADOR	1	1	
57	703-82563-30	.TRIM & TILT SWITCH ASSY .INTERRUPTOR DE INCLINACION	1	1	WITH PT/T SW. WITH PT/T SW.
58	703-48284-00	.GROMMET .TAPON	1	1	
59	703-82591-00	.BAND .BANDA	1	1	
60	703-82592-00	.BAND .BANDA	1	1	
61	703-48153-00	.SHAFT, FREE ACCEL. .EJE	1	1	



63PD370-P330

FIG. 25 REMOTE CONTROL ASSY 2 CONTROL REMOTO COMPL 2

REF. NO.	PART NO. CODIGO Nº	DESCRIPTION DESCRIPCION	ET	E/O	REMARKS OBSERVACIONES
1	703-48207-20	REMOTE CONTROL ASSY (10P, PTT) REMOTO CONTROL COMPL. (10P)		1	AP FOR BRA,ARG AP FOR BRA,ARG
2	703-48232-00	.GEAR .ENGRANAJE 1		1	
3	703-48271-00	.ARM, SHIFT .BRAZO CAMBIADOR		1	
4	703-48261-01	.ARM, THROTTLE .BRAZO ACELERADOR		1	
5	703-48235-00	.BUSHING .BUJE		1	
6	703-48152-10	.KNOB, FREE ACCEL. .PERILLA		1	
7	703-48268-00	.SPACER .ESPACIADOR 3		1	
8	703-48264-00	.FRICTION, THROTTLE .FRICCION DE ACELERADOR		1	
9	95380-05600	.NUT .TUERCA		1	
10	97380-05025	.BOLT .TORNILLO HEXAGONAL		1	
11	703-48265-00	.SHAFT, FRICTION .EJE FRICCION		1	
12	93430-06024	.CIRCLIP .SEGURO		3	
13	703-48245-00	.PLATE, LOCK .PLACA CERRADURA		1	
14	703-48252-00	.ROLLER, CAM .RODILLO LEVA		1	
15	701-48248-00	.ROLLER, FREE ACCEL. .RODILLO ACELERADOR LIBRE		1	
16	703-48198-00	.WASHER, WAVE .RONDANA ONDULADA 3		1	
17	703-48243-00	.BUSHING .BUJE 3		1	
18	703-48236-00	.BUSHING 1 .BUJE		2	
19	703-48189-00	.RETAINER .RETENEDOR		1	
20	703-48234-00	.ROLLER, DETENT .RODILLO		1	
21	703-48345-01	.CABLE END, REMOTE CONTROL 2 .TERMINAL CABLE DE CONTROL REMO		2	
22	703-48358-00	.ANCHOR, CABLE .ABRAZADERA CABLE		1	
23	703-48244-00	.SPRING, FREE ACCEL. .RESORTE ACELERADOR LIBRE		1	
24	703-48238-00	.SPRING, DETENT .RESORTE		5	
25	703-48211-10	.HOUSING,1 .CAJA		1	
26	703-48212-10	.BACK PLATE 1 .PLACA TRASERA 1		1	
27	703-48213-10	.BACK PLATE 2 .PLACA TRASERA 2		1	

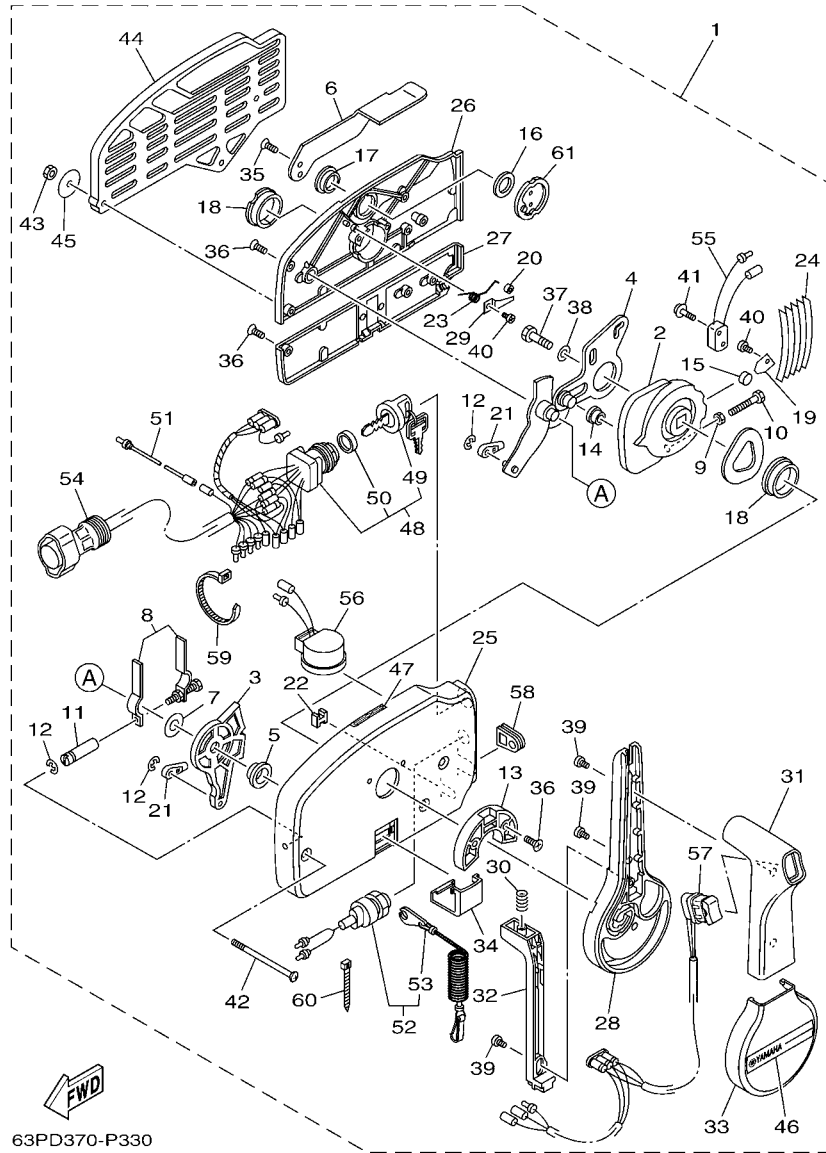

63PD370-P330

FIG. 25 REMOTE CONTROL ASSY 2 CONTROL REMOTO COMPL 2

REF. NO.	PART NO. CODIGO Nº	DESCRIPTION DESCRIPCION	ET	E/O	REMARKS OBSERVACIONES
28	703-48221-10	.LEVER, CONTROL .PALANCA CONTROL		1	
29	703-48246-00	.SPACER .ESPACIADOR		1	
30	703-48227-00	.SPRING, NEUTRAL LOCK .RESORTE DE SEGURO		1	
31	703-48222-20	.GRIP, CONTROL LEVER .MANGO DE PALANCA CONTROL		1	SINGLE SINGLE
32	703-48223-10	.LOCK, NEUTRAL .CERRADURA NEUTRO		1	
33	703-48225-10	.COVER .CUBIERTA		1	
34	703-48219-10	.COVER, LEAD .CUBIERTA		1	
35	703-48281-00	.SCREW .TORNILLO 1		2	
36	703-44189-20	.SCREW .TORNILLO		7	
37	97380-08030	.BOLT .TORNILLO HEXAGONAL		1	
38	92990-08600	.WASHER, PLATE .ARANDELA PLANA		1	
39	703-48128-10	.SCREW 2 .TORNILLO 2		3	
40	98580-04006	.SCREW, PAN HEAD .TORNILLO DE CABEZA CRUZADA		2	
41	703-48129-00	.SCREW 3 .TORNILLO 3		2	
42	703-44189-30	.SCREW .TORNILLO		3	
43	95380-06600	.NUT, HEXAGON .TUERCA		3	
44	703-48293-10	.SPACER, REMOTE CONTROL .ESPACIADOR		1	SINGLE SINGLE
45	701-48287-00	.WASHER .ARANDELA		3	
46	703-48215-10	.GRAPHIC .CALCOMANIA 1		1	
47	6X3-44191-00	.INDICATOR, SHIFT .INDICADOR DE CAMBIOS		1	
48	703-82510-44	.MAIN SWITCH ASSY .CONJUNTO DE LLAVE IGNICION		1	
49	703-82577-00	..CAP, KEY ..TAPA		1	
50	6K1-82532-00	..CAP ..TAPA		1	
51	703-82531-00	.WIRE, LEAD (L70) .CABLE CONDUCTOR (L70)		1	
52	688-82575-01	.ENGINE STOP SWITCH ASSY .INTERRUPTOR DE PARADA COMPL		1	
53	682-82556-00	..LANYARD, STOP SWITCH ..CORDON DE INTERRUPTOR PARADA		1	
54	688-8258A-20	.EXTENSION, WIRE HARNESS (4.9M) .EXTENSION, ARNES DE CABLES (4.		1	(10P) (10P)

FIG. 25 REMOTE CONTROL ASSY 2 CONTROL REMOTO COMPL 2

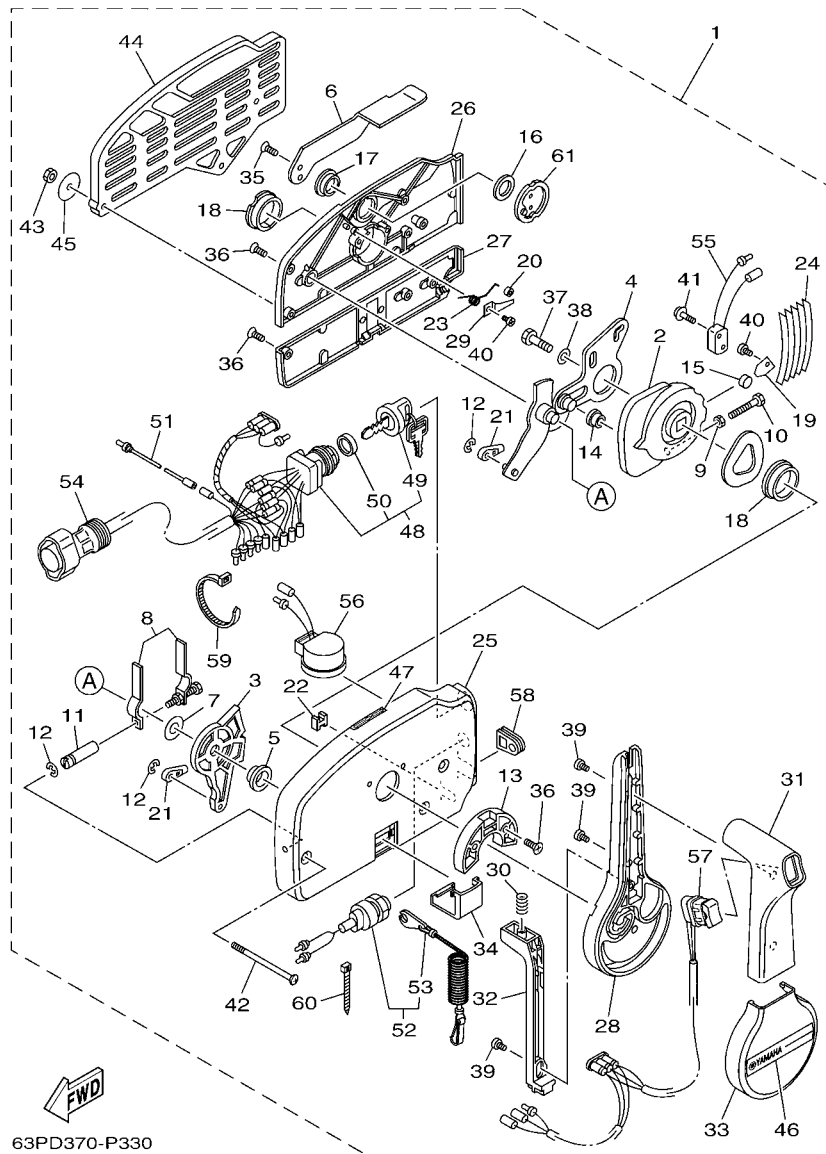

63PD370-P330

REF. NO.	PART NO. CODIGO Nº	DESCRIPTION DESCRIPCION	ET	ETO	REMARKS OBSERVACIONES
55	703-82540-00	.NEUTRAL SWITCH ASSY .INTERRUPTOR NEUTRAL COMPL		1	
56	703-83383-11	.BUZZER .ZUMBADOR		1	
57	703-82563-20	.TRIM & TILT SWITCH ASSY .INTERRUPTOR DE INCLINACION		1	WITH PT/T SW. WITH PT/T SW.
58	703-48284-10	.GROMMET .TAPON		1	
59	703-82591-00	.BAND .BANDA		1	
60	703-82592-00	.BAND .BANDA		1	
61	703-48153-00	.SHAFT, FREE ACCEL. .EJE		1	

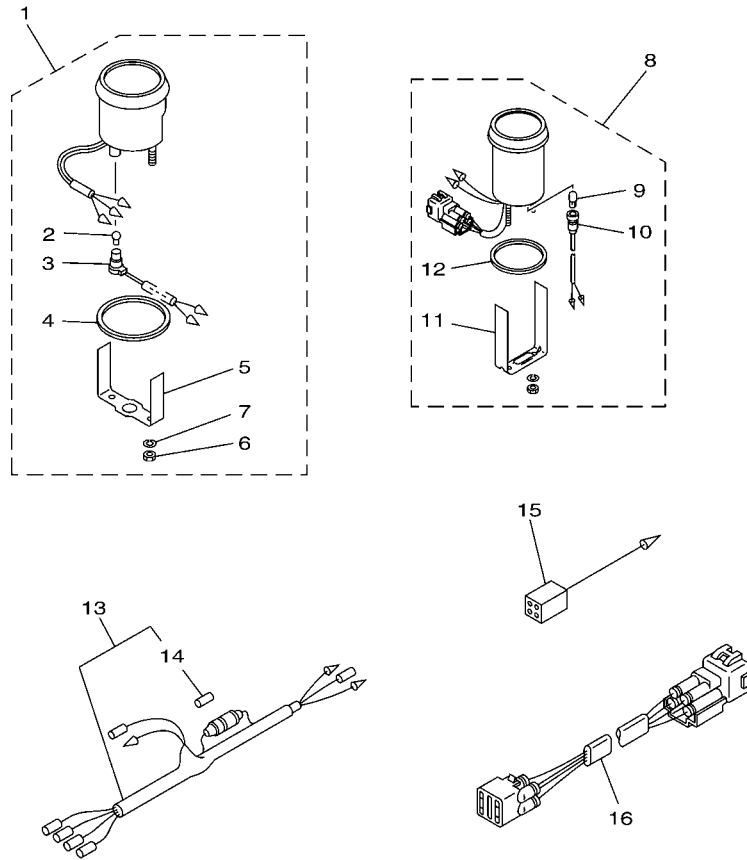

6H37200-G260

FIG. 26 METER 1

MEDIDOR 1

REF. NO.	PART NO. CODIGO Nº	DESCRIPTION DESCRIPCION	ET	EYO		REMARKS OBSERVACIONES
1	6Y7-83540-20	TACHOMETER ASSY TACOMETRO COMPLETO	1			AP FOR CHN AP FOR CHN
2	6Y5-83517-00	.BULB (T10, 12V-1.7W) .BOMBILLA (T10, 12V-1.7W)	1			
3	6Y5-83536-40	.SOCKET, METER .ENCASTRE DE MEDIDOR	1			
4	6Y5-83523-00	.DAMPER .AMORTIGUADOR	1			
5	6Y5-83514-00	.PLATE, FITTING .PLACA ACCESORIA	1			
6	95380-05600	.NUT .TUERCA	2			
7	92990-05100	.WASHER, SPRING .ARANDELA PLANA	2			
8	6Y7-83670-00	TRIM METER ASSY. MEDIDOR DE INCLINACION	1			AP AP
9	6Y5-83518-00	.BULB (12V-1.7W T6.5) .BOMBILLA (12V-1.7W T6.5)	1			
10	6Y5-83536-00	.SOCKET, METER .ENCASTRE DE MEDIDOR	1			
11	6Y5-83544-00	.PLATE, FITTING .PLACA ACCESORIA	1			
12	688-83664-00	.DAMPER .AMORTIGUADOR	1			
13	6Y5-83553-00	WIRE, LEAD (L=2.5M) CABLE CONDUCTOR (L=2.5M)	1			AP AP
14	1E6-82151-00	.FUSE (10A) .FUSIBLE (10A)	1			
15	6Y5-82117-00	WIRE, LEAD (BLACK) (L300) CABLE, CONDUCTOR (NEGRO)	1			AP FOR CHN AP FOR CHN
16	6R3-82553-70	EXTENSION, WIRE LEAD (L=7.0M) CABLE (L=7.0M)	1			AP (4P) AP (4P)

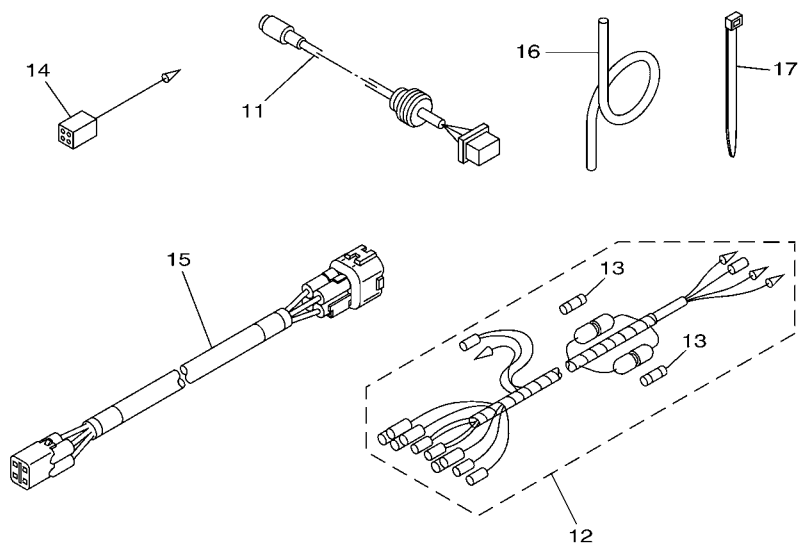
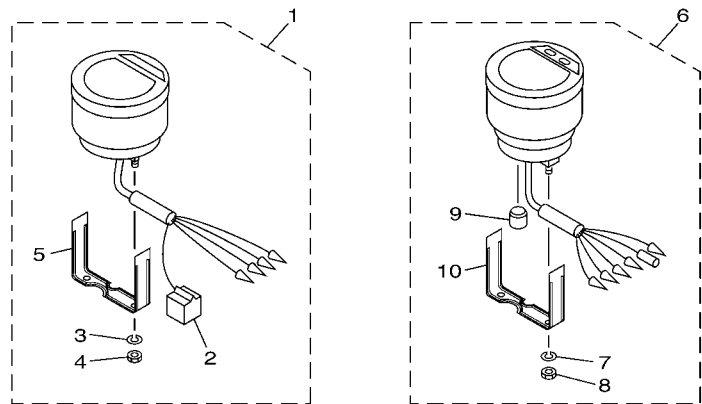

6C14100-G370

FIG. 27 METER 2

MEDIDOR 2

REF. NO.	PART NO. CODIGO Nº	DESCRIPTION DESCRIPCION	ET	EPO	REMARKS OBSERVACIONES
1	6Y5-8350T-91	DIGITAL TACHOMETER ASSY TACOMETRO DIGITAL COMPLETO		1	AP
2	9E450-04533	.CONNECTOR .CONECTOR		1	F-4-W F-4-W
3	92990-04100	.WASHER, SPRING .ARANDELA PLANA		2	
4	95380-04600	.NUT .TUERCA		2	
5	6Y5-8355X-T1	.BRACKET, METER 1 .SOSTEN		1	
6	6Y5-83570-S6	SPEEDOMETER ASSY VELOCIMETRO COMPLETO		1	AP FOR BRA AP FOR BRA
7	92990-04100	.WASHER, SPRING .ARANDELA PLANA		2	
8	95380-04600	.NUT .TUERCA		2	
9	6Y5-83533-T2	.GROMMET .ANILLO PROTECTOR		1	
10	6Y5-8355X-T1	.BRACKET, METER 1 .SOSTEN		1	
11	6Y5-87122-S0	CORD ASSY 1 CABLE COMPLETA 1		1	AP AP
12	6Y5-83553-M0	WIRE, LEAD (L=2.5M) CABLE CONDUCTOR (L=2.5M)		1	AP FOR BRA AP FOR BRA
	6Y5-83553-00	WIRE, LEAD (L=2.5M) CABLE CONDUCTOR (L=2.5M)		1	AP EXCEPT FOR BRA AP EXCEPT FOR BRA
13	1E6-82151-00	.FUSE (10A) .FUSIBLE (10A)		2	FOR 6Y5-83553-M0 FOR 6Y5-83553-M0
	1E6-82151-00	.FUSE (10A) .FUSIBLE (10A)		1	FOR 6Y5-83553-00 FOR 6Y5-83553-00
14	6Y5-82117-00	WIRE, LEAD (BLACK) (L300) CABLE, CONDUCTOR (NEGRO)		1	AP FOR BRA AP FOR BRA
15	6Y5-83653-20	WIRE, LEAD (L=7.0M) CABLE CONDUCTOR (L=7.0M)		1	AP 4P,7M AP 4P,7M
16	6Y5-83557-10	TUBE (8M) TUBO (8M)		1	AP FOR BRA AP FOR BRA
17	90465-11M10	CLAMP BRIDA		1	AP FOR BRA AP FOR BRA



FIG. 28 REPAIR KIT 1

ESTUCHE REPARATION 1

REF. NO.	PART NO. CODIGO Nº	DESCRIPTION DESCRIPCION	ET	EPO	REMARKS OBSERVACIONES
1	6H3-W0001-02	POWER HEAD GASKET KIT JUEGO DE EMPAQUE	1	1	AUTO CHOKE AUTO CHOKE
2	6H3-11181-A2	.GASKET, CYLINDER HEAD 1 .JUNTA, DE CULATA 1	1	1	
3	90430-14115	.GASKET .JUNTA	1	1	
4	6H3-11193-A1	.GASKET, HEAD COVER 1 .EMPAQUE	1	1	
5	6H3-12414-A1	.GASKET, COVER .EMPAQUE	1	1	
6	6H3-41112-A0	.GASKET, EXHAUST INNER COVER .EMPAQUE	1	1	
7	6H3-41114-A0	.GASKET, EXHAUST OUTER COVER .EMPAQUE	1	1	
8	93102-36M24	.OIL SEAL .SELLO ACEITE	1	1	
9	93210-46M16	.O-RING .ANILLO O	1	1	
10	93102-30M23	.OIL SEAL .SELLO ACEITE	1	1	
11	93106-18M01	.OIL SEAL .SELLO ACEITE	1	1	
12	93210-65M50	.O-RING .ANILLO O	1	1	
13	6H3-13621-A1	.GASKET, VALVE SEAT .JUNTA, DE VALV.DE EMPAQUE	1	1	
14	93210-39ME4	.O-RING .ANILLO O	3	3	
15	6H4-14984-00	.GASKET, FLOAT CHAMBER .EMPAQUE CAMARA DE BOIA	3	3	
16	93210-32738	.O-RING .ANILLO O	1	1	
17	650-24431-A0	.GASKET, FUEL PUMP 1 .EMPAQUE BOMBA COMBUST 1	1	1	
18	6H3-45113-A0	.GASKET, UPPER CASING .EMPAQUE	1	1	
19	6H3-13622-A1	.GASKET, VALVE SEAT .EMPAQUE DE ASIENTO VALVULA	1	1	
20	6H2-W0093-10	CARBURETOR REPAIR KIT KIT REPARACION CARBURADOR	1	1	AUTO CHOKE AUTO CHOKE
21	6H4-14147-00	.O-RING .ANILLO O	1	1	
22	93210-04228	.O-RING .ANILLO O	1	1	
23	6H3-14590-01	.NEEDLE VALVE ASSY .VALVULA DE AGUJA COMPLETA	1	1	
24	6H4-14548-00	.PIN, FLOAT ARM .PASADOR DE BRAZO DE BOIA	1	1	
25	663-14159-00	.CLIP .PRESILLA	1	1	
26	676-14186-00	.PIN, FLOAT .PASADOR DE LA BOYA	1	1	
27	676-14966-00	.CAP .TAPA	1	1	

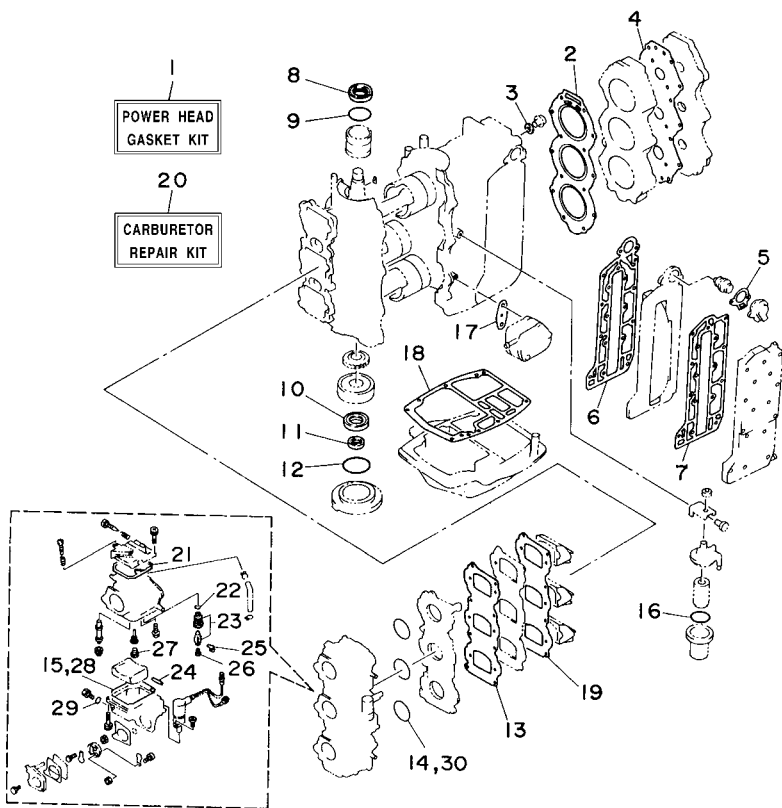

  
6H30010-4230

FIG. 28 REPAIR KIT 1

ESTUCHE REPARACION 1

REF. NO.	PART NO. CODIGO Nº	DESCRIPTION DESCRIPCION	ET	ETO	REMARKS OBSERVACIONES
28	6H4-14984-00	.GASKET, FLOAT CHAMBER .EMPAQUE CAMARA DE BOIA	1	1	
29	93210-04230	.O-RING .ANILLO O	1	1	
30	93210-39ME4	.O-RING .ANILLO O	1	1	
-----					
-----					
-----					
-----					
-----					
-----					
-----					
-----					
-----					
-----					
-----					
-----					

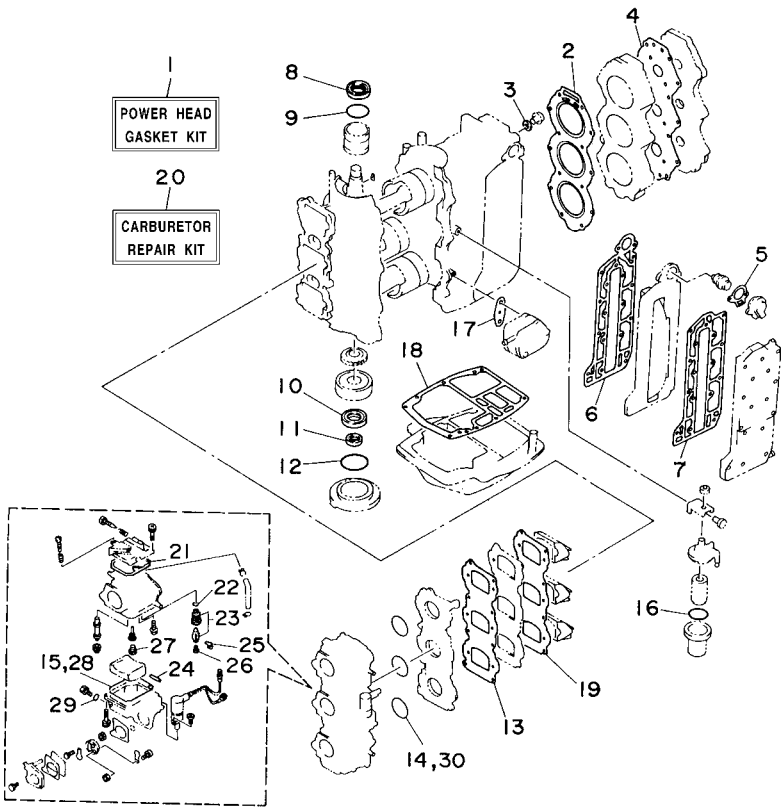

  
6H30010-4230

FIG. 29 REPAIR KIT 2

ESTUCHE REPARACION 2

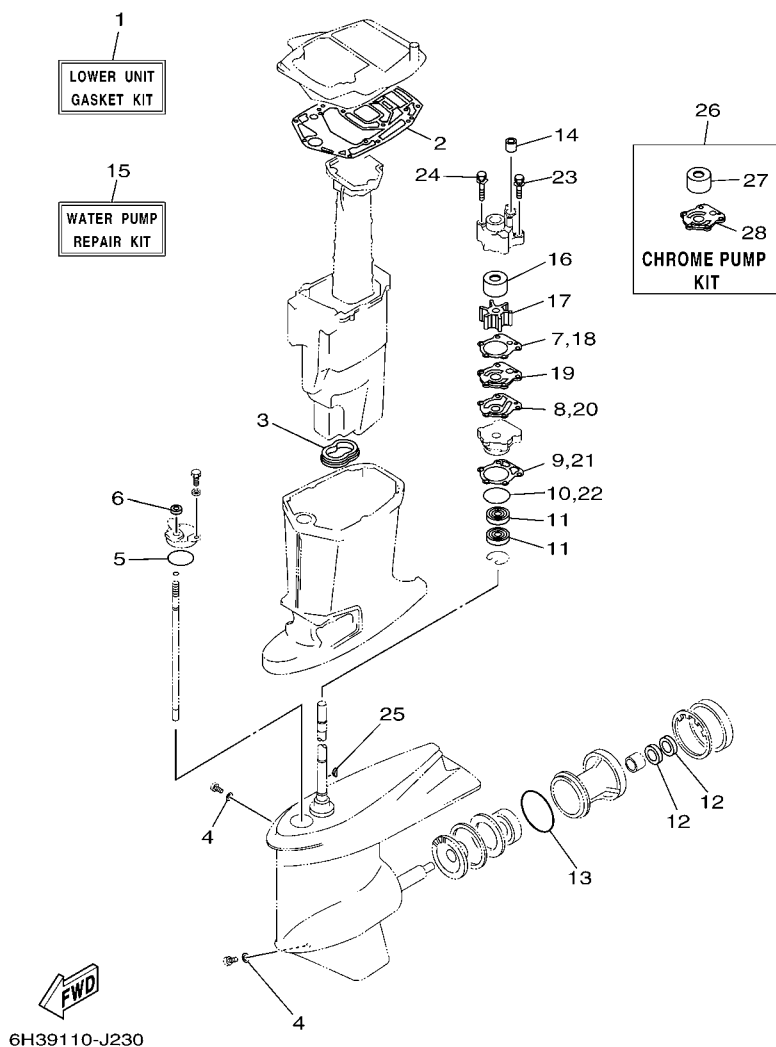

REF. NO.	PART NO. CODIGO Nº	DESCRIPTION DESCRIPCION	ET	EPO	REMARKS OBSERVACIONES
1	6H2-W0001-20	LOWER UNIT GASKET KIT JUEGO DE JUNTA UNIDAD INFERIOR	1	1	L(20.5") L(20.5")
2	6H3-45114-A1	.GASKET, UPPER CASING .EMPAQUE	1	1	
3	6H3-45123-00	.GASKET, MUFFLER .EMPAQUE SILENCIADOR	1	1	
4	90430-08020	.GASKET .JUNTA	2	2	
5	93210-49046	.O-RING .ANILLO O	1	1	
6	93106-09014	.OIL SEAL .SELLO ACEITE	1	1	
7	688-44315-A0	.GASKET, WATER PUMP .EMPAQUE	1	1	
8	688-44324-A0	.GASKET, CARTRIDGE .EMPAQUE	1	1	
9	688-44316-A0	.GASKET, WATER PUMP .EMPAQUE	1	1	
10	93210-46044	.O-RING .ANILLO O	1	1	
11	93101-25M03	.OIL SEAL .SELLO ACEITE	2	2	
12	93101-25M03	.OIL SEAL .SELLO ACEITE	2	2	
13	93210-85M97	.O-RING .ANILLO O	1	1	
14	663-44366-00	.DAMPER, WATER SEAL 2 .GOMA DEL SELLO DE AGUA 2	1	1	
15	692-W0078-02	WATER PUMP REPAIR KIT ESTUCHE REPARACION BOMBA AGUA	1	1	L(20.5") L(20.5")
16	688-44322-00	.INSERT, CARTRIDGE .CARTUCHO	1	1	
17	688-44352-03	.IMPELLER .IMPULSOR	1	1	
18	688-44315-A0	.GASKET, WATER PUMP .EMPAQUE	1	1	
19	688-44323-00	.OUTER PLATE, CARTRIDGE .PLACA EXTERIOR DEL CARTUCHO	1	1	
20	688-44324-A0	.GASKET, CARTRIDGE .EMPAQUE	1	1	
21	688-44316-A0	.GASKET, WATER PUMP .EMPAQUE	1	1	
22	93210-46044	.O-RING .ANILLO O	1	1	
23	90119-08M13	.BOLT, WITH WASHER .TORNILLO CON ARANDELA	2	2	
24	90119-08M16	.BOLT, WITH WASHER .TORNILLO CON ARANDELA	2	2	
25	90280-04M04	.KEY, WOODRUFF .CUNA WOODRUFF	1	1	
26	6H3-W0078-1B	CHROME PUMP KIT ESTUCHE REPARACION BOMBA AGUA	1	1	L(20.5") L(20.5")
27	69D-44322-00	.INSERT, CARTRIDGE .CARTUCHO	1	1	

FIG. 29 REPAIR KIT 2

ESTUCHE REPARATION 2

REF. NO.	PART NO. CODIGO Nº	DESCRIPTION DESCRIPCION	ET	ETO				REMARKS OBSERVACIONES
28	688-44323-40	.OUTER PLATE, CARTRIDGE .PLACA EXTERIOR DEL CARTUCHO	1	1				

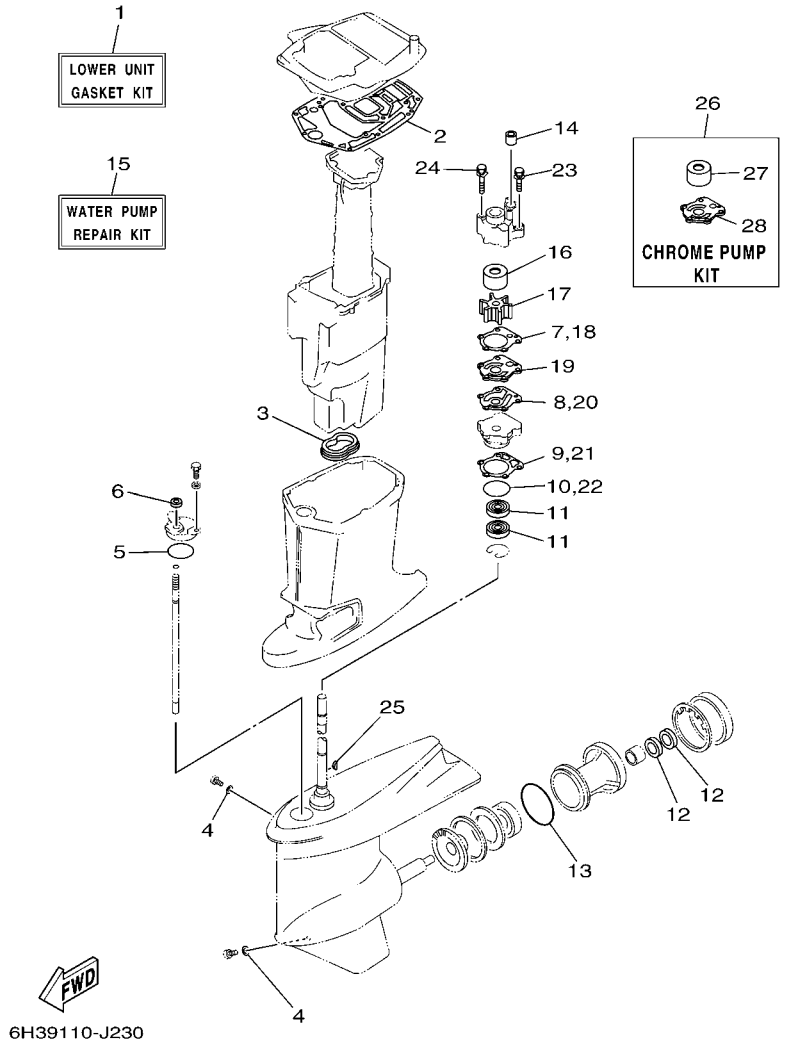

NUMERICAL INDEX  
INDICE NUMERICO

PART NO. CODIGO N°	REF. NO.	PART NO. CODIGO N°	REF. NO.	PART NO. CODIGO N°	REF. NO.	PART NO. CODIGO N°	REF. NO.	PART NO. CODIGO N°	REF. NO.	PART NO. CODIGO N°	REF. NO.
6H3-11111-01-1S	4 - 25	6H3-13641-14	6 - 4	6H3-14948-13	7 - 22	692-24411-00	9 - 17	6H2-42610-10	2 - 1	6H3-42727-00	13 - 19
688-11119-01	4 - 21	6H3-13641-22	6 - 4	6H3-14948-16	7 - 22	6H3-24411-10	7 - 39	6H2-42610-70	3 - 1	6H3-42738-01-CA	13 - 16
6H3-11181-A2	4 - 26	6H3-14137-00	7 - 30	6H3-14948-17	7 - 22	6A0-24412-02	9 - 26	6H3-42613-01-4D	2 - 11	6H3-42741-01-4D	13 - 31
	28 - 2	6H4-14146-00	7 - 8	676-14966-00	7 - 21	6A0-24413-00	9 - 16		3 - 12	6BG-42748-00	13 - 20
6H3-11191-00-1S	4 - 27	6H4-14147-00	7 - 9		28 - 27	6H4-24413-00	7 - 37	6H3-42615-00	2 - 14	6G1-42748-00	13 - 30
6H3-11193-A1	4 - 28		28 - 21	6H4-14980-00	7 - 26	6L5-24421-00	7 - 36		3 - 15	6H3-42768-00	13 - 23
	28 - 4	663-14159-00	7 - 16	6H3-14980-10	7 - 27	6A0-24421-01	9 - 24	6H3-42617-00	2 - 15	6H3-42771-01-4D	13 - 32
6H3-11325-01	1 - 1		28 - 25	6H4-14984-00	7 - 23	650-24431-A0	9 - 27	6H3-42617-10	3 - 16	6EE-42794-40	13 - 40
	4 - 17	676-14186-00	7 - 17		28 - 15		28 - 17	6H3-42619-00	2 - 16	6EE-42794-50	13 - 41
6H3-11327-00-94	4 - 18		28 - 26		28 - 28	648-24434-01	9 - 18		3 - 17	6AH-42794-70	13 - 40
6H3-11328-00	4 - 19	6H3-14301-20	7 - 1	6H4-14985-01	7 - 18	6H3-24434-10	7 - 40	6H3-4261A-00	2 - 2	6H3-42813-00	13 - 7
650-11370-01	4 - 4	6H2-14301-40	7 - 1	6H3-14992-00	7 - 24	648-24435-02	9 - 21	6H3-4261A-10	3 - 2	6H3-42815-01-4D	13 - 3
688-11370-01	4 - 3	6H2-14301-50	7 - 1	6H3-15100-06	4 - 2	6H3-24452-10	7 - 28	6H3-42627-00	2 - 17	6H3-42816-00	13 - 9
6H3-11400-03	5 - 7	6H3-14302-20	7 - 2	6H3-15100-14	4 - 2	6H4-24486-00	7 - 38		3 - 18	6H3-42817-01-4D	13 - 4
6H3-11400-10	5 - 7	6H2-14302-40	7 - 2	6H3-15359-00-94	5 - 1	61N-24521-00	9 - 8	6H3-42637-00	2 - 18	6H3-42818-00	13 - 10
6H3-11536-00	5 - 12	6H2-14302-50	7 - 2	6H3-21707-06	8 - 26	61N-24560-00	9 - 6		3 - 19	6H1-43111-01-4D	15 - 1
6H3-11537-01	8 - 16	6H3-14303-20	7 - 3	6H3-21732-00	3 - 21	61N-24563-00	1 - 5	6H3-42647-00	2 - 3	6H1-43112-00-4D	15 - 10
6K5-11601-02	5 - 15	6H2-14303-40	7 - 3	6H3-21735-00	3 - 22		9 - 7		3 - 4	6E5-43126-10	15 - 33
6K5-11601-12	5 - 15	6H2-14303-50	7 - 3	63D-21744-00	8 - 53	648-24566-02	9 - 10	6H3-42649-00	2 - 4	688-43131-03	15 - 19
6K5-11601-22	5 - 15	6A0-14325-00	9 - 25	6H3-21752-00	8 - 32	6YJ-24610-01	21 - 2		3 - 5	6G5-43144-00	15 - 40
6H3-11631-01-96	5 - 14	6H3-14349-00	6 - 15	6H1-21757-00	8 - 38	6H1-24633-00	8 - 39	6H3-42652-00	2 - 6	6E5-43145-01	22 - 9
6H3-11633-00	5 - 16		7 - 31	6J8-21758-00	8 - 37	6E0-28193-00	9 - 39		3 - 7	6G5-43145-01	15 - 23
688-11634-10	5 - 17	6H3-14380-00	7 - 32	63D-2175R-00	8 - 35	6H3-41111-01-1S	4 - 37	663-42662-00	2 - 5	6G5-43148-00	15 - 38
6H3-11635-01	5 - 14	6H3-14413-11	6 - 17	6H1-21766-01	8 - 44	6H3-41112-A0	4 - 38		3 - 6	688-43160-01	15 - 29
6H3-11636-01	5 - 14	6H3-14440-02	6 - 18	63D-2176M-00	8 - 34		28 - 6	688-42675-40	2 - 21	688-43165-00	15 - 30
6H3-12411-11	1 - 2	6H3-14457-01	6 - 19	6H4-21770-00	8 - 36	6H3-41113-02-1S	4 - 39		3 - 27	6H1-43181-01	15 - 24
	4 - 32	624-14485-00	4 - 5	63D-2177H-00	3 - 3	6H3-41114-A0	4 - 40	688-42676-40	2 - 22	6H1-43185-01	15 - 25
688-12412-00	4 - 33	6H1-14485-00	6 - 5	6YJ-24167-00	21 - 7		28 - 7		3 - 28	6H1-43311-02-4D	15 - 15
6H3-12413-00-1S	4 - 34		6 - 5	6YJ-24201-00	21 - 1	6H2-41131-00-CA	18 - 10	6H2-42678-10	2 - 19	6H1-43376-00	16 - 38
6H3-12414-A1	1 - 3	6K5-14488-00	6 - 23	6YJ-24260-00	21 - 3	6H3-41131-00-CA	18 - 10		2 - 20	6H1-43800-17-8D	17 - 1
	4 - 35	63V-14523-00	7 - 5	6Y1-24268-00	21 - 6	6H3-41137-01-CA	18 - 5		3 - 25	67F-43802-00	17 - 37
	28 - 5	6H4-14548-00	7 - 14	6G1-24304-02	9 - 1	6H3-41213-30	14 - 23		3 - 26	6H1-43804-10	17 - 4
6H1-13117-01	8 - 18		28 - 24	6G1-24305-05	21 - 13	6H3-41217-00	6 - 12	6H3-42678-10	3 - 25	6H1-43805-10	17 - 3
6E9-13183-70	8 - 11	697-14555-00	7 - 11	6Y1-24305-06	21 - 15	682-41237-00	14 - 2		3 - 26	6H1-4380F-10	17 - 7
6H3-13200-02	8 - 1	6H4-14567-00	7 - 29	61J-24306-04	21 - 8	6E9-41237-00	8 - 25	688-42681-40	2 - 23	6H1-4380G-10	17 - 15
6J8-13411-00	8 - 40	6H2-14578-00	7 - 7	663-24312-01	4 - 42	6F5-41237-00	14 - 15		2 - 24	6H1-4380H-10	17 - 13
6J8-13414-00	8 - 41	6H3-14590-01	7 - 13	6H3-24313-00	9 - 33	6H1-41237-00	8 - 21		3 - 30	6H1-4380J-10	17 - 8
6H1-13435-00	8 - 42		28 - 23	6H3-24314-00	9 - 35		14 - 14		3 - 31	6H1-43810-12	17 - 20
6H3-13436-00	3 - 29	6H3-14711-11-CA	18 - 12	6Y1-24329-00	21 - 5	6H4-41237-00	14 - 21	6H1-42694-00	3 - 20	6H1-43812-00	17 - 23
6H3-13436-40	3 - 29	6H3-14737-10	18 - 17	650-24351-51	21 - 12	6H3-41241-01	8 - 20	6H3-42711-25-4D	13 - 1	6H1-43813-10	17 - 25
6H3-13437-21	10 - 22	692-14923-00	7 - 10	61J-24360-00	21 - 10	6H3-41631-00	14 - 4	648-42715-00	14 - 28	6H1-43814-11	17 - 19
6H2-13610-00	6 - 1	6H3-14943-35	7 - 20	6E5-24367-01	13 - 24	6H3-41632-20	14 - 10	6H3-42716-02	13 - 12	6H1-43816-00	17 - 65
6H3-13610-00	6 - 1	6H3-14943-36	7 - 20		13 - 37	6H3-41633-10	14 - 12	6K5-42717-00	13 - 13	6H1-43817-01	17 - 45
6H3-13621-A1	6 - 6	6H3-14943-37	7 - 20	650-24378-00	4 - 6	6H3-41636-10	14 - 16	6H3-42718-00	13 - 39	6E5-43818-00	17 - 30
	28 - 13	676-14943-38	7 - 20	688-24378-00	9 - 32	689-42169-01	14 - 1	6E5-42724-00	13 - 14	6H1-43820-11	17 - 61
6H3-13622-A1	6 - 8	6H1-14943-39	7 - 20	6E5-24378-00	8 - 55		14 - 20	6H3-42725-10	13 - 15	6H1-43821-11	17 - 57
	28 - 19	6H2-14947-71	7 - 19	692-24410-00	9 - 15	6H3-42510-13-4D	16 - 3	6H3-42725-30	13 - 15	6H1-43822-10	17 - 56
6H3-13624-00	6 - 7	6H3-14947-71	7 - 19	663-24411-00	9 - 20	6H3-42610-00	3 - 1	688-42726-10	13 - 27	6H1-43828-10	17 - 28

NUMERICAL INDEX  
INDICE NUMERICO

PART NO. CODIGO N°	REF. NO.	PART NO. CODIGO N°	REF. NO.	PART NO. CODIGO N°	REF. NO.	PART NO. CODIGO N°	REF. NO.	PART NO. CODIGO N°	REF. NO.	PART NO. CODIGO N°	REF. NO.
6H1-43829-00	17 - 34	703-44189-20	25 - 36	6H3-45127-00	18 - 13	6H1-45631-01	19 - 45	703-48212-10	25 - 26	703-48271-00	25 - 3
6H1-4382A-10	17 - 50	703-44189-30	24 - 42	6C5-45155-00	18 - 3	688-45633-00	19 - 56	703-48213-10	24 - 27	703-48281-00	24 - 35
6H1-43830-11	17 - 47		25 - 42	6H1-45214-00	19 - 12	6H1-45634-02	19 - 47		25 - 27		25 - 35
6H1-43831-10	17 - 46	6X3-44191-00	24 - 47	6H1-45215-00	19 - 13	6H1-45635-00	19 - 51	703-48215-10	24 - 46	703-48284-00	24 - 58
6H1-43833-10	17 - 31		25 - 47	6H1-45251-03	1 - 7	6H1-45641-01	19 - 57		25 - 46	703-48284-10	25 - 58
6H1-43834-00	17 - 32	688-44194-00	14 - 7		15 - 2	6H1-45668-00	19 - 50	703-48219-10	24 - 34	701-48287-00	24 - 45
6H1-43835-10	17 - 27	688-44311-01	19 - 25	6H3-45300-17-4D	19 - 1	688-45930-02	20 - 24		25 - 34		25 - 45
6H1-43840-12	17 - 17	688-44315-A0	19 - 27	6H1-45301-03-4D	19 - 2	688-45932-60	20 - 24	703-48221-10	24 - 28	703-48293-10	24 - 44
6H1-43841-11	17 - 40		29 - 7	688-45321-00	19 - 16	6E5-45941-00	20 - 24		25 - 28		25 - 44
6H1-43843-11	17 - 69		29 - 18	688-45331-00-CA	19 - 64	6E5-45943-00	20 - 24	703-48222-20	24 - 31	701-48320-20	23 - 2
6H1-43844-10	17 - 42	688-44316-A0	19 - 34	688-45341-10	19 - 10	6E5-45945-01	20 - 24		25 - 31	701-48320-30	23 - 2
6H1-43845-00	17 - 53		29 - 9	67F-45371-00	1 - 9	6E5-45947-00	20 - 24	703-48223-10	24 - 32	701-48320-40	23 - 2
6H1-43847-00	17 - 48		29 - 21		20 - 12	6E5-45949-00	20 - 24		25 - 32	663-48344-00	14 - 41
6H1-4384E-20	17 - 59	688-44322-00	19 - 26	6E5-45371-10	1 - 10	6E5-45952-00	20 - 24	703-48225-10	24 - 33	6H3-48344-00	14 - 18
6H1-4384F-10	17 - 44		29 - 16		20 - 27	6E5-45954-00	20 - 24		25 - 33	703-48345-01	24 - 21
6H1-4384G-11	17 - 43	69D-44322-00	19 - 26	688-45375-00	20 - 11	6E5-45956-00	20 - 24	703-48227-00	24 - 30		25 - 21
6H1-43854-00	17 - 51		29 - 27	663-45376-00	20 - 10	688-45970-03	20 - 24		25 - 30	703-48358-00	24 - 22
6H1-43855-11	17 - 68	688-44323-00	19 - 35	6E5-45378-00	19 - 21	6E5-45970-10	20 - 25	703-48232-00	24 - 2		25 - 22
6H1-43856-10	17 - 41		29 - 19	688-45383-02	19 - 72	688-45972-02	20 - 24		25 - 2	6H3-48511-52	16 - 35
6H1-4385H-00	17 - 74	688-44323-40	19 - 35	688-45384-02	19 - 73	6E5-45972-10	20 - 25	703-48234-00	24 - 20	6H3-48538-00	14 - 42
6D8-43861-00	17 - 24		29 - 28	6H3-45501-11	19 - 40	688-45974-02	20 - 24		25 - 20	688-61350-10	22 - 1
6H1-43861-00	17 - 21	688-44324-A0	19 - 36	688-45536-01	19 - 4	6E5-45974-10	20 - 25	703-48235-00	24 - 5	688-61351-10	22 - 2
6H1-43861-10	17 - 18		29 - 8	6K5-45551-00	19 - 41	688-45976-01	20 - 24		25 - 5	6E5-61355-00	22 - 8
	17 - 58		29 - 20	6K5-45560-00	19 - 43	6E5-45976-10	20 - 25	703-48236-00	24 - 18	6H4-81315-11	11 - 51
6H1-43862-00	17 - 22	6D8-44341-01-CA	19 - 30	688-45567-01	19 - 7	6E5-45978-10	20 - 25		25 - 18	6E5-81332-00	10 - 15
6D8-43863-00	17 - 54	688-44352-03	19 - 28	688-45567-10	19 - 7	688-45978-60	20 - 24	703-48238-00	24 - 24	6H3-81337-01	10 - 17
6H1-43864-00	17 - 62		29 - 17	688-45567-20	19 - 7	688-45987-01	20 - 19		25 - 24	6H3-81800-11	12 - 1
6H1-43865-10	17 - 16	6H3-44361-11	20 - 2	688-45567-30	19 - 7	6E5-45994-10	20 - 26	703-48243-00	24 - 17	6H3-81807-10	12 - 3
6H1-43866-01	17 - 38	663-44366-00	20 - 16	688-45567-40	19 - 7	67F-45997-00	20 - 20		25 - 17	689-81809-11	12 - 7
6H1-43868-00	17 - 71		29 - 14	688-45567-50	19 - 7	703-48128-10	24 - 39	703-48244-00	24 - 23	6H3-81810-10	12 - 9
6H1-4386K-10	17 - 9	663-44367-00	20 - 1	688-45567-60	19 - 7		25 - 39		25 - 23	689-81811-11	12 - 12
6H1-43874-00	17 - 64	69D-44391-00	13 - 2	6H3-45571-00	19 - 63	703-48129-00	24 - 41	703-48245-00	24 - 13	689-81812-11	12 - 11
6H1-43875-00	17 - 55	688-44511-00	16 - 33	688-45576-00	19 - 67		25 - 41		25 - 13	689-81813-10	12 - 13
6H1-4387J-00	17 - 73	688-44514-00	16 - 26	688-45577-01	19 - 66	703-48152-10	24 - 6	703-48246-00	24 - 29	6H3-81820-11	12 - 14
6H1-43880-02	17 - 2	6EK-44536-00	15 - 3	688-45577-10	19 - 66		25 - 6		25 - 29	689-81826-10	12 - 15
6H1-43881-10	17 - 12	6H3-44551-01-4D	16 - 9	688-45577-20	19 - 66	703-48153-00	24 - 61	701-48248-00	24 - 15	6H3-81830-10	12 - 4
6H1-4388E-11	17 - 70	6H3-44552-03	16 - 18	688-45577-30	19 - 66		25 - 61		25 - 15	689-81831-00	12 - 5
6H1-43891-10	17 - 5	6H3-44553-01-4D	16 - 23	688-45577-40	19 - 66	703-48189-00	24 - 19	703-48252-00	24 - 14	689-81840-11	12 - 10
6H1-43892-10	17 - 6	687-44555-00	16 - 11	688-45577-50	19 - 66		25 - 19		25 - 14	689-81847-11	12 - 6
6H1-43895-12	17 - 67	663-44575-00	16 - 16	688-45577-60	19 - 66	703-48198-00	24 - 16	703-48261-01	24 - 4	689-81850-12	12 - 8
6H1-43899-00	17 - 49		16 - 32	688-45587-01	19 - 5		25 - 16		25 - 4	689-81857-11	12 - 2
6H3-44117-00-94	14 - 31	6H3-45111-12-4D	18 - 1	688-45587-10	19 - 5	703-48205-B0	23 - 1	703-48264-00	24 - 8	6H3-81916-10	11 - 14
6H3-44120-13	14 - 27	6H3-45113-A0	18 - 7	688-45587-20	19 - 5		24 - 1		25 - 8	6H2-81949-01	11 - 43
6H3-44121-01	14 - 37		28 - 18	688-45587-30	19 - 5	703-48207-20	23 - 1	703-48265-00	24 - 11	6H2-81949-11	11 - 42
688-44122-00	14 - 40	6H3-45114-A1	18 - 15	688-45587-40	19 - 5		25 - 1		25 - 11	61A-81950-00	11 - 38
6H1-44144-00	19 - 59		29 - 2	688-45587-50	19 - 5	703-48211-10	24 - 25	703-48268-00	24 - 7	688-81950-10	11 - 23
6H1-44151-00	19 - 58	6H3-45123-00	18 - 14	688-45587-60	19 - 5		25 - 25		25 - 7	6H2-81960-10	11 - 10
703-44189-20	24 - 36		29 - 3	6H1-45611-01	19 - 44	703-48212-10	24 - 26	703-48271-00	24 - 3	6EE-81994-40	6 - 24

NUMERICAL INDEX  
INDICE NUMERICO

PART NO. CODIGO N°	REF. NO.	PART NO. CODIGO N°	REF. NO.	PART NO. CODIGO N°	REF. NO.	PART NO. CODIGO N°	REF. NO.	PART NO. CODIGO N°	REF. NO.	PART NO. CODIGO N°	REF. NO.
6EE-81994-50	6 - 25	6H2-82590-13	11 - 30	6H2-W0001-20	29 - 1	90171-16011	20 - 22	90386-13M38	13 - 5	90464-07M05	4 - 16
6AH-81994-70	6 - 24	6H2-82590-80	11 - 30	688-W0004-00	6 - 2	90179-06066	16 - 22	90386-18M14	17 - 29		8 - 5
6EE-81995-40	10 - 19	703-82591-00	24 - 59	692-W0078-02	1 - 11	90179-08M34	4 - 31	90386-18M35	15 - 35		8 - 15
6EE-81995-50	10 - 20		25 - 59		29 - 15	90183-02M03	19 - 54	90386-18M63	15 - 34	90464-11M18	15 - 17
6AH-81995-70	10 - 19	703-82592-00	24 - 60	6H3-W0078-1B	29 - 26	90183-05M06	3 - 24	90386-22M15	15 - 20	90464-11M23	8 - 58
6AG-81996-00	10 - 21		25 - 60	6H3-W0090-44-1S	4 - 1	90185-05002	19 - 15	90386-30M60	16 - 8	90464-15M11	8 - 8
6H3-82105-02	11 - 28	688-82594-00	11 - 36	6H3-W0090-60-1S	4 - 1	90185-08057	16 - 39	90386-30M77	16 - 6		11 - 27
6H3-82117-00	11 - 29	703-83383-11	24 - 56	6H2-W0093-10	28 - 20	90185-09M01	22 - 4	90386-30M78	16 - 5	90464-16021	13 - 28
6Y5-82117-00	26 - 15		25 - 56	656-W2810-02	9 - 38	90185-10027	16 - 31	90387-06119	8 - 48	90464-18M14	11 - 49
	27 - 14	6Y5-8350T-91	27 - 1	90101-08002	4 - 22		16 - 37	90387-06289	14 - 8	90464-23M22	11 - 17
703-82119-00	11 - 6	6Y5-83514-00	26 - 5	90101-10041	16 - 27	90185-22043	15 - 22		14 - 25	90465-06M86	8 - 10
	16 - 41	6Y5-83517-00	26 - 2	90101-12M65	15 - 42	90201-03313	19 - 53	90387-06M31	8 - 31	90465-11M10	16 - 40
682-82119-01	11 - 44	6Y5-83518-00	26 - 9	90105-06M14	11 - 2	90201-08M93	8 - 17	90387-06M43	11 - 3		19 - 24
688-82127-02	16 - 25	6Y5-83523-00	26 - 4	90105-10M67	20 - 13	90201-10M20	22 - 3	90387-06M69	13 - 21		27 - 17
6E5-82148-00	15 - 11	6Y5-83533-T2	27 - 9	90109-06M39	8 - 3	90201-10M63	22 - 7	90387-10M02	15 - 27	90465-11M27	8 - 28
6H1-82148-00	15 - 8	6Y5-83536-00	26 - 10	90109-06M40	8 - 4	90201-11M22	16 - 30	90387-10M42	22 - 6	90465-13M11	11 - 18
1E6-82151-00	26 - 14	6Y5-83536-40	26 - 3	90109-06M43	14 - 13	90201-12062	15 - 43	90389-25M00	20 - 21	90465-13M30	8 - 33
	27 - 13	6Y7-83540-20	26 - 1	90109-12M21	16 - 15	90201-12426	15 - 44	90430-08020	1 - 8	90465-18147	7 - 41
	27 - 13	6Y5-83544-00	26 - 11	90116-08M69	4 - 30	90201-12M16	16 - 12		19 - 11	90467-06016	4 - 11
663-82151-00	11 - 31	6Y5-83553-00	26 - 13	90116-10062	16 - 36	90201-13M19	16 - 14		29 - 4		4 - 15
6G5-82152-00	11 - 16		27 - 12	90119-06023	4 - 20	90201-20417	5 - 19	90430-12072	20 - 4		6 - 14
6H3-82154-11	11 - 41	6Y5-83553-M0	27 - 12	90119-06M09	13 - 11	90201-20M21	16 - 28	90430-14115	4 - 24	90467-08004	4 - 43
6H3-82164-00	11 - 26	6Y5-83557-10	27 - 16	90119-06M29	15 - 4	90201-21M18	10 - 14		28 - 3		6 - 16
6A0-82317-00	8 - 47	6E5-83558-00	20 - 15	90119-06M61	13 - 22	90201-22M67	15 - 21	90440-14M00	15 - 46		8 - 45
6G1-82370-21	11 - 22	6E5-83558-10	19 - 23	90119-06M65	8 - 49	90201-30M00	16 - 4	90445-07255	6 - 13		9 - 5
703-82510-13	24 - 48	6Y5-8355X-T1	27 - 5	90119-06M88	8 - 50	90202-05088	8 - 22	90445-07M02	4 - 12		9 - 14
703-82510-44	25 - 48		27 - 10	90119-06MA3	4 - 36	90202-07M07	14 - 39	90445-07M23	8 - 7		9 - 31
703-82531-00	24 - 51	6Y5-83570-S6	27 - 6		6 - 9	90202-12060	20 - 3	90445-07M44	4 - 10		9 - 36
	25 - 51	6E5-83614-01	11 - 47	90119-06MA5	4 - 41	90202-20M06	16 - 29		8 - 6	90467-10M04	8 - 52
6K1-82532-00	25 - 50	6Y5-83653-20	27 - 15	90119-08M13	19 - 39	90202-25M04	16 - 13	90445-07M45	4 - 13	90467-11M08	8 - 29
703-82532-00	24 - 50	688-83664-00	26 - 12		29 - 23	90206-10M04	14 - 24	90445-07M82	4 - 14		8 - 59
703-82540-00	24 - 55	6Y7-83670-00	26 - 8	90119-08M16	19 - 38	90206-13M10	13 - 6	90445-07M87	8 - 9	90467-12M11	8 - 46
	25 - 55	6H1-83672-13	16 - 1		29 - 24	90209-06M05	6 - 21	90445-07ME9	19 - 22	90468-05M03	8 - 23
6R3-82553-70	26 - 16	6H1-83672-21	16 - 1	90119-08M64	4 - 9	90249-06M19	15 - 37	90445-07MF1	20 - 14	90468-07M02	8 - 12
682-82556-00	24 - 53	6H2-85520-02	10 - 2	90119-08M81	18 - 4	90250-07M02	19 - 55	90445-08M01	8 - 43		8 - 13
	25 - 53	6H2-85533-01	10 - 3	90119-08MA5	4 - 29	90266-06009	2 - 10	90445-09072	9 - 13		8 - 14
688-82560-10	11 - 37	6H2-85540-13	11 - 5	90119-10005	4 - 8		3 - 11		9 - 30	90468-18008	14 - 19
6H1-82563-11	11 - 45	6H3-85542-11	11 - 1	90151-05M00	19 - 14	90269-04M03	13 - 8	90445-09220	9 - 34		14 - 38
703-82563-20	25 - 57	6H2-85550-01	10 - 1	90157-05M19	21 - 4	90280-04M04	19 - 29	90445-09M75	9 - 4	90480-13M54	11 - 4
703-82563-30	24 - 57	697-85570-00	11 - 19	90157-06M01	13 - 25		29 - 25	90445-11M02	8 - 57	90480-19M06	20 - 17
688-82575-01	24 - 52	6H2-85580-01	10 - 4		13 - 29	90280-05015	10 - 12	90445-11M03	8 - 27	90501-10326	7 - 6
	25 - 52	6H2-85582-00	10 - 5	90157-06M13	14 - 5	90282-04010	19 - 71	90445-11M05	21 - 11	90501-12082	14 - 30
703-82577-00	25 - 49	6H1-85711-60	6 - 22	90159-06M01	11 - 15	90338-05M03	3 - 23	90445-11M06	21 - 9	90501-12M48	19 - 52
676-82577-01	24 - 49	6R5-85711-60	11 - 50	90159-06M23	10 - 18		15 - 18	90445-11M15	8 - 54	90501-14M08	16 - 21
6R5-82582-B0	8 - 61	6H3-85720-17	8 - 60	90160-04006	20 - 18	90340-08002	19 - 9	90445-11M21	8 - 51	90501-16M65	19 - 48
6E5-82587-00	11 - 46	6H2-85895-01	10 - 6	90170-09M03	22 - 5	90340-14M06	4 - 23	90446-10M01	8 - 56	90502-16M02	15 - 32
688-8258A-20	24 - 54	6Y5-87122-S0	27 - 11	90170-16M01	19 - 42	90386-07M58	14 - 34		9 - 37	90506-14M24	15 - 39
	25 - 54	6H3-W0001-02	28 - 1	90170-20137	10 - 13	90386-10M16	15 - 26	90464-05M16	11 - 13	90508-26M35	14 - 11

NUMERICAL INDEX  
INDICE NUMERICO

PART NO. CODIGO N°	REF. NO.	PART NO. CODIGO N°	REF. NO.	PART NO. CODIGO N°	REF. NO.	PART NO. CODIGO N°	REF. NO.	PART NO. CODIGO N°	REF. NO.	PART NO. CODIGO N°	REF. NO.
91318-04025	17 - 72	93101-25M03	19 - 32	93306-306V1	5 - 11	97013-06012	11 - 34	97607-04310	17 - 11		
91318-08016	17 - 63		19 - 70	93311-636U6	5 - 8	97013-06014	9 - 12	97803-04010	7 - 33		
91490-20012	14 - 36		29 - 11	93315-325V1	19 - 3	97013-06016	11 - 24	97880-06012	15 - 12		
91490-30025	20 - 23		29 - 12	93317-325U0	19 - 69	97013-06020	11 - 20	97885-05016	17 - 10		
91690-30012	15 - 31	93102-08M43	17 - 14	93332-000U3	19 - 6		14 - 32	97885-06016	16 - 24		
91690-30020	15 - 28	93102-30M23	5 - 2	93332-000W7	19 - 8	97013-06025	12 - 18	97885-06045	6 - 20		
92903-06600	7 - 43		28 - 10	93410-18M05	15 - 36	97013-08016	12 - 20	97980-04114	7 - 4		
	11 - 9	93102-36M24	5 - 9	93410-28M06	16 - 10	97013-08035	12 - 16	97980-05216	6 - 3		
	11 - 21		28 - 8	93430-06024	24 - 12	97075-08025	16 - 19	97985-06210	10 - 16		
	11 - 25	93106-09014	19 - 18		25 - 12	97075-10040	20 - 6	97985-06216	16 - 2		
	11 - 33		29 - 6	93440-49M04	5 - 10	97095-05012	10 - 7	98503-05028	9 - 22		
	11 - 35	93106-18M01	5 - 3	93450-07M00	19 - 62	97095-06010	15 - 41	98580-04006	24 - 40		
	12 - 19		28 - 11	93450-44166	19 - 31	97095-06016	2 - 7		25 - 40		
	14 - 33	93210-04228	7 - 12	93501-04M02	14 - 29		2 - 12	98580-04008	7 - 15		
92903-08600	12 - 17		28 - 22	93503-16003	19 - 49		3 - 8	98980-03006	7 - 35		
	12 - 21	93210-04230	7 - 25	93505-32038	17 - 75		3 - 13	99001-08600	19 - 61		
92990-04100	27 - 3		28 - 29	93603-12M11	19 - 46		8 - 30	9E450-04533	27 - 2		
	27 - 7	93210-064A5	17 - 36	93603-18M09	5 - 18		11 - 11				
92990-05100	9 - 23	93210-07003	19 - 60	93604-10M03	19 - 37		11 - 48				
	26 - 7	93210-08287	21 - 14	93606-12019	18 - 2		13 - 17				
92990-06600	13 - 26		21 - 16		18 - 6		15 - 5				
	13 - 38	93210-09165	17 - 35		20 - 5		19 - 19				
92990-08200	14 - 35	93210-10M74	17 - 52	93608-12063	4 - 7	97095-06020	5 - 5				
92990-08600	24 - 38	93210-11368	17 - 66	93700-06M03	15 - 16		13 - 35				
	25 - 38	93210-12N52	17 - 39	94702-00160	1 - 4	97095-06025	9 - 2				
92990-10100	20 - 7	93210-13M04	8 - 19		4 - 44		10 - 10				
92990-10600	20 - 8	93210-16275	22 - 10	94702-00247	1 - 4		11 - 39				
92995-06100	2 - 8	93210-19MA7	8 - 2		4 - 44		13 - 33				
	3 - 9	93210-29M94	16 - 7	95380-03600	7 - 34		14 - 9				
	15 - 6	93210-32738	1 - 6		9 - 19		14 - 26				
92995-06600	2 - 9		9 - 9	95380-04600	27 - 4	97095-06035	10 - 8				
	2 - 13		28 - 16		27 - 8	97095-06040	9 - 28				
	3 - 10	93210-39ME4	6 - 11	95380-05600	8 - 24	97095-06095	6 - 10				
	3 - 14		28 - 14		14 - 3	97095-10045	15 - 13				
	5 - 6		28 - 30		14 - 17	97380-05025	24 - 10				
	9 - 3	93210-46044	19 - 33		14 - 22		25 - 10				
	9 - 29		29 - 10		24 - 9	97380-08030	24 - 37				
	10 - 9		29 - 22		25 - 9		25 - 37				
	10 - 11	93210-46M16	5 - 13		26 - 6	97575-08530	18 - 8				
	11 - 12		28 - 9	95380-06600	14 - 6		18 - 11				
	11 - 40	93210-49046	19 - 17		24 - 43		18 - 16				
	13 - 18		29 - 5		25 - 43	97575-08535	16 - 34				
	13 - 34	93210-65M50	5 - 4	95380-08600	9 - 11		18 - 9				
	13 - 36		28 - 12	95380-12600	15 - 45	97575-08560	20 - 9				
	15 - 7	93210-68N50	17 - 26	95380-12800	16 - 17	97595-06420	17 - 33				
	19 - 20	93210-85M97	19 - 68	97013-06012	7 - 42	97595-06510	15 - 9				
92995-08600	16 - 20		29 - 13		11 - 8	97595-06545	11 - 7				
92995-10600	15 - 14	93306-207U0	19 - 65		11 - 32	97602-05210	17 - 60				